

4a impetus (PART 1): Dynamic material characterization of plastics – development in the past 10 years

A. Fertschej, P. Reithofer, M. Rollant

4a engineering GmbH

1 Introduction

In recent years plastics have been used more and more in automotive industry primarily

- for cost reasons in complex design,
 - for safety reasons in the area of occupant and pedestrian safety application and
 - for CO₂ reduction reasons in lightweight applications with regard to structural performance needs.
- Therefore simulation of the application load cases is an indispensable must have in the product development. Based on the successful usage of simulation tools in the metallic section, the standard simulation methods and material models can't represent the plastic material behavior. Many developments and improvements in the crashcode LS-DYNA especially for plastics and composites have been seen in the past 10 years, with the necessity to consider the deformation (viscoelasticity, viscoplasticity, anisotropy) as well as damage and failure behavior in the material model.

2 Retrospect

New developments in the testing and material characterization have been going along with requirements of these new models [1]. The classic testing methods ideally with mechanical understanding (tension, compression and shear) with local strain measurements (for example by DIC) are one approach to deal with this topic.

Another approach is to use the bending load case and its many advantages:

- this is the most frequently occurring load case in reality,
- the geometry of the test specimens can be very simple and
- tests can be performed very quickly and accurate using 4a impetus (see fig. 1).

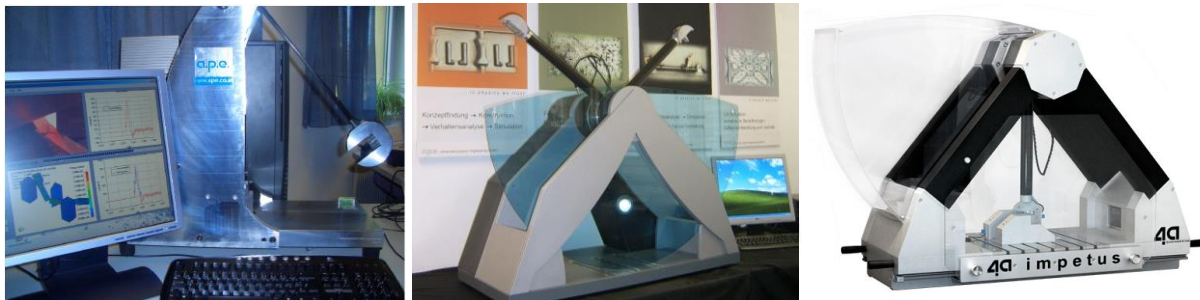

Fig. 1: Prototype of 4a impetus (2004 [2]), first commercial version (2006 [3]) and the current version (2015 [4])

In the presentation we will give an exemplary overview of the development in the field of plastic materials testing in the past 10 years

- starting with simple *MAT_024 and high-speed tensile tests compared to the easy 4a impetus bending approach,
- showing the reverse engineering process with LS-OPT and the normal and clamped bending as alternative to high speed tensile tests,
- considering different loading situations (e.g. *MAT_187), needed test specimens and methods to characterize the material,
- including temperature and moisture dependencies for thermoplastics and
- concluding with current developments in considering the process influence and in failure prediction.

3 State of the art

In the field of old school material characterization static and dynamic tensile tests are the base for a *MAT_024 material card generation. For plastics and composites there is no high-speed tensile testing standard method available. Considering complex yield surfaces (tension, shear, compression, ...) or anisotropy is often a known issue and well researched in several public founded projects, but cannot be seen as standard in automotive simulation applications.

4a impetus stands for the new solution, starting from measurement data handling up to an automatic material parameter identification process (MPIP) based on reverse engineering. The hardware and software products are used by automotive OEMs and their suppliers, material suppliers, research institutes and engineering service providers. Meanwhile 4a offers standards to generate simple material cards like *MAT_024, considering anisotropy *MAT_054/058/157, compression/tension behavior *MAT_124/187.

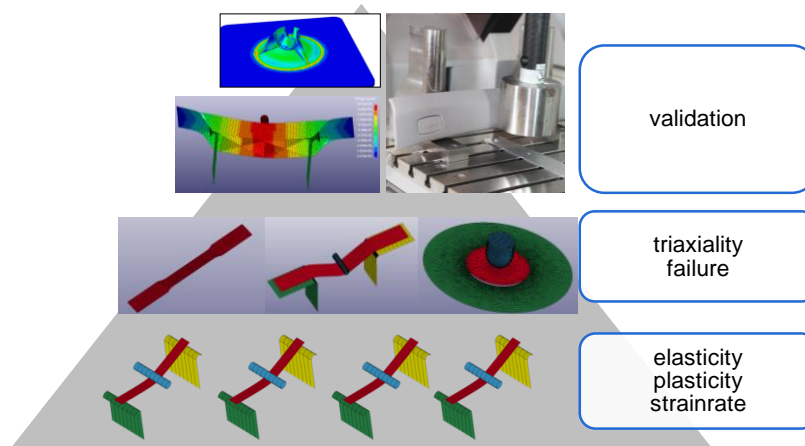

Fig.2: 4a impetus material characterization pyramid for plastics [5], [6],[7]

4 Summary & Outlook

Driven by the increasing requirements of the industry to predict not only the "average" deformation behavior, the simulation methods and the therefore needed material models as well as the testing methods have to be improved continuously. 4a impetus is the first approach, closing the gap between the simulation and testing fractions.

Due to lightweight applications and the mechanical structural relevance of plastic and composite materials especially damage and failure prediction as well as considering process induced inhomogeneity (e.g. short and long fiber reinforced materials, foamed plastics, ...) will be R&D topics in the next years.

5 Literature

- [1] Kolling, St. et.al.: *SAMP-1: A Semi-Analytical Model for the Simulation of Polymers*, 4. LS-DYNA Anwenderforum, Bamberg 2005
- [2] Hafellner, R. et. al: *Neue flexible Methoden der Materialdatenermittlung für die dynamische Simulation*, 3. LS-DYNA Anwenderforum, Bamberg 2004
- [3] Fritz, M. et. al: *Kunststoffcharakterisierung mit Impetus II - Der effiziente Weg zu validierten dynamischen Materialdaten*, LS-DYNA Forum, Frankenthal 2007
- [4] <http://impetus.4a.co.at>
- [5] Reithofer, P. et. al: *Dynamic Material Characterization Using 4a impetus*, 29th Regional Conference of the Polymer Processing Society, Graz 2015
- [6] Fertschej, A. et. al: *Failure models for thermoplastics in LS-DYNA*, 29th Regional Conference of the Polymer Processing Society, Graz 2015
- [7] Reithofer, P. et. al: *Zeitabhängiges Materialverhalten von Kunststoffen*, 4a. Technologietag, Schladming 2016

4a impetus (PART 1): Dynamic material characterization of plastics development in the past 10 years

P. Reithofer, A. Fertschej, M. Rollant (4a engineering GmbH)

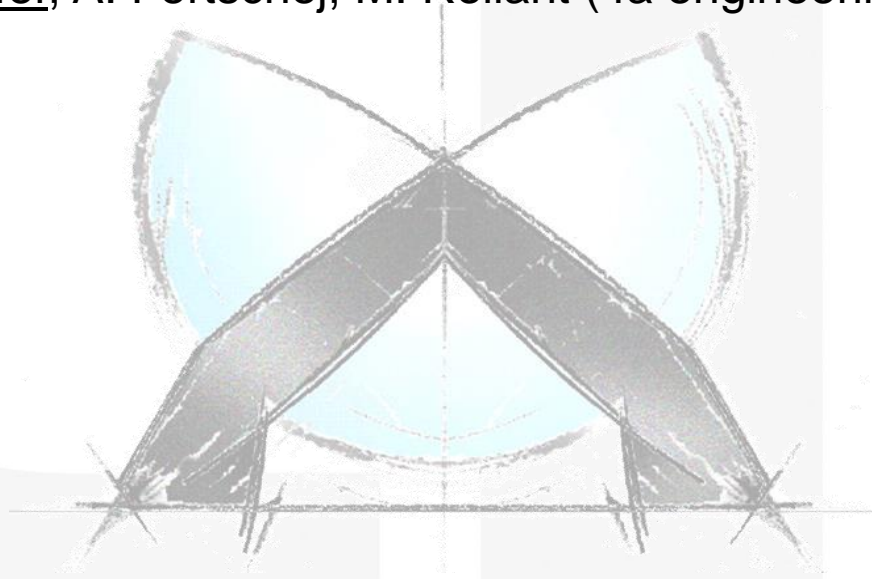

**14th German LS-DYNA Conference
10th – 12th October 2016, Bamberg, Germany**

4a engineering GmbH
Industriepark 1
A-8772 Traboch
reithofer@4a.co.at
++43 (0) 664 80106 601

© 4a engineering GmbH, all rights reserved

4a technology-group: founded in 2002

Location: Traboch, Austria

Number of employees > 80

Field of operation: global

Certificates: ISO 9001

more than 2000 projects

more than 400 customers

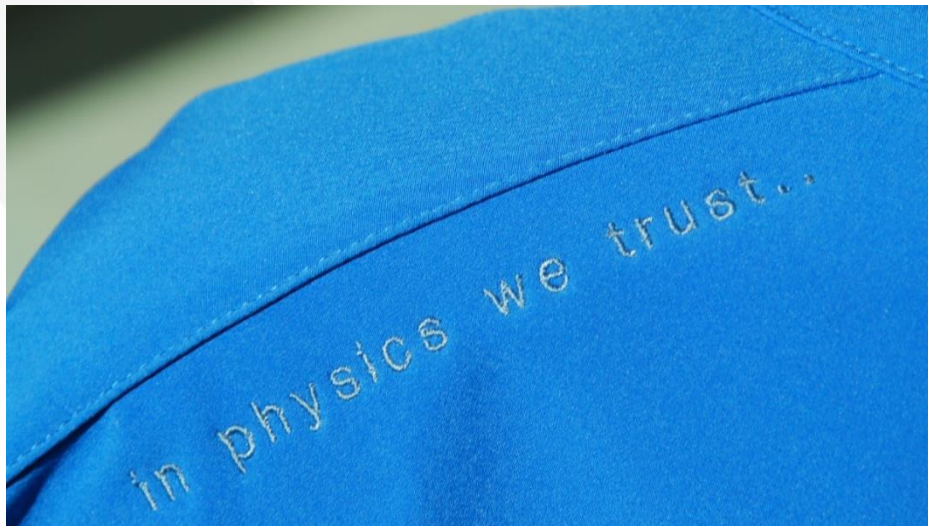

- polymer and materials science
- numerical simulation methods
- fiber reinforced plastics and composites
- product development
- method and software development
- material characterization

strut bar:



LH₂ – tank mounting:

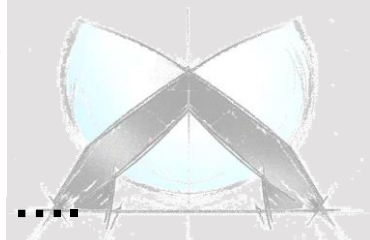
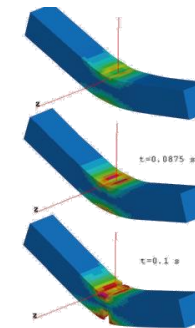
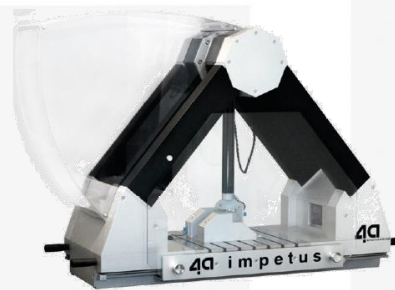
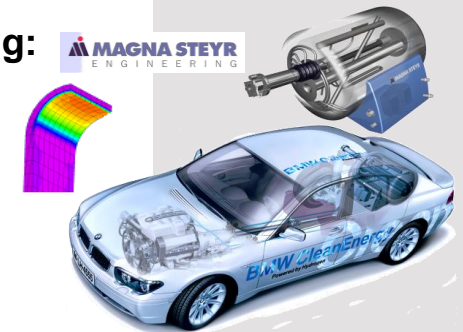

validated material cards for plastics, composites, metals, foams,

material variety

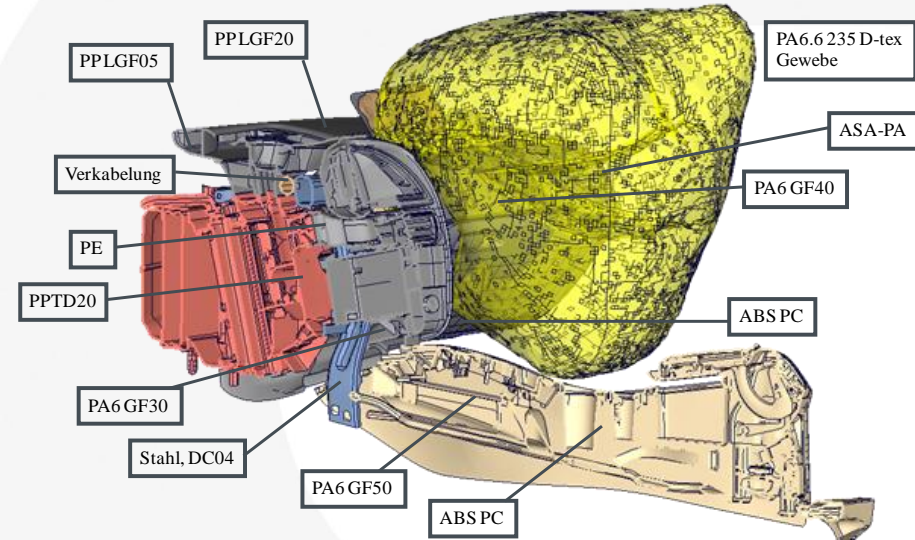

bending load case

original test curve tension

scaling 1.25

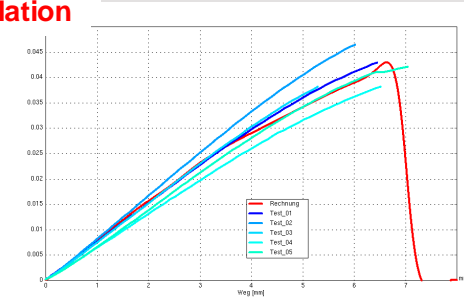
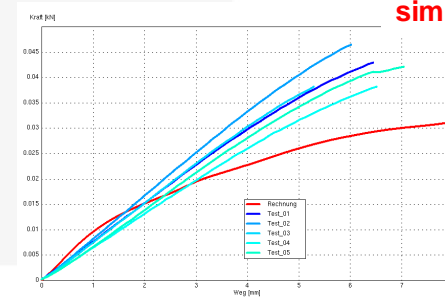
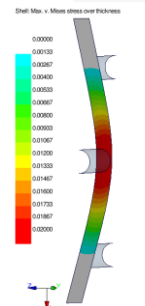
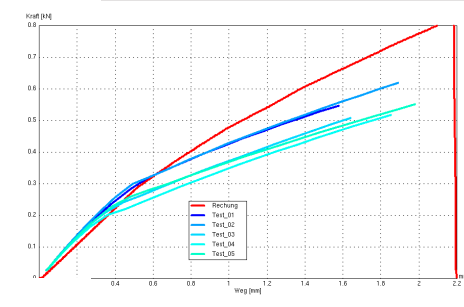
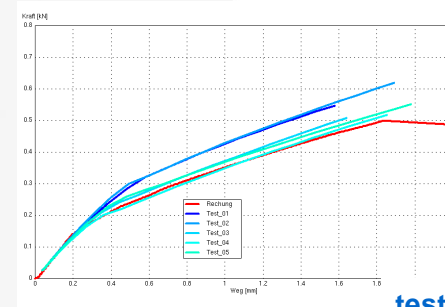
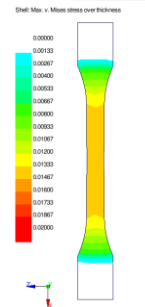

R. Luijckx - Kunststoffmaterialien in der Interieur
 Funktionsauslegung bei Audi AG, 4a Technologietag 2010

Dynamic material characterization of plastics first steps

2004

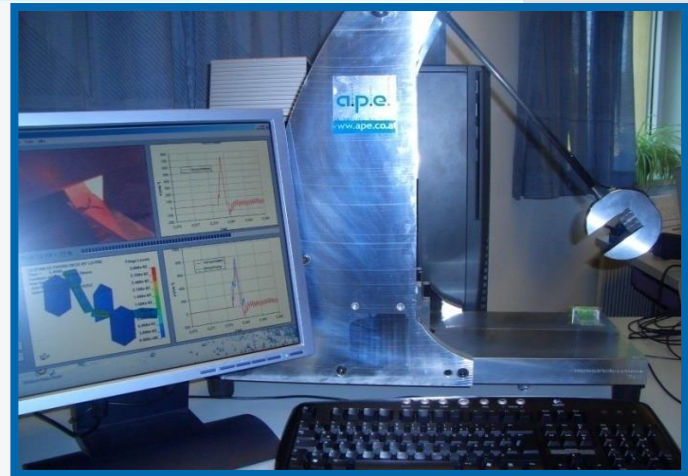
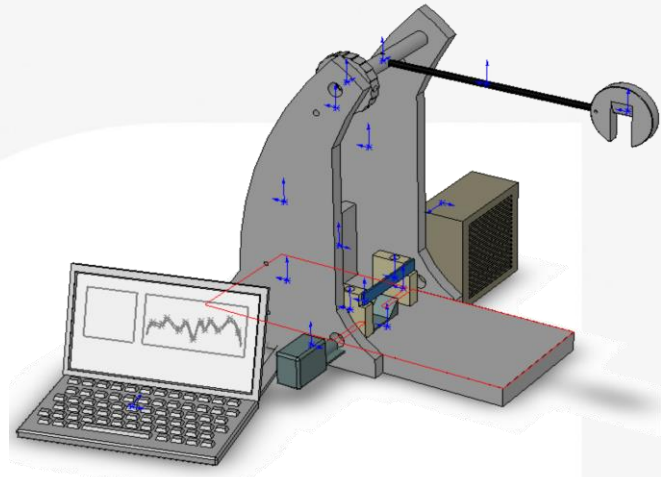

2005

2006

2007



2008

2009

4a impetus Hardware

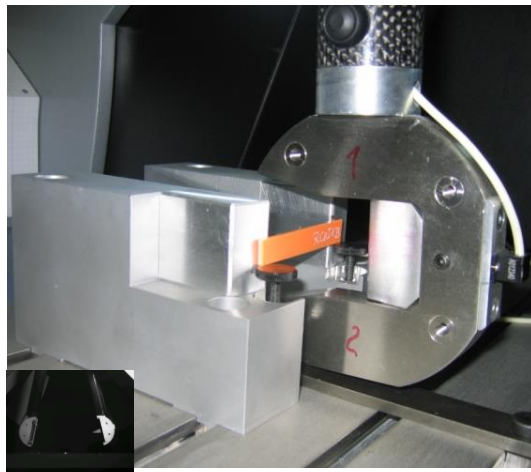
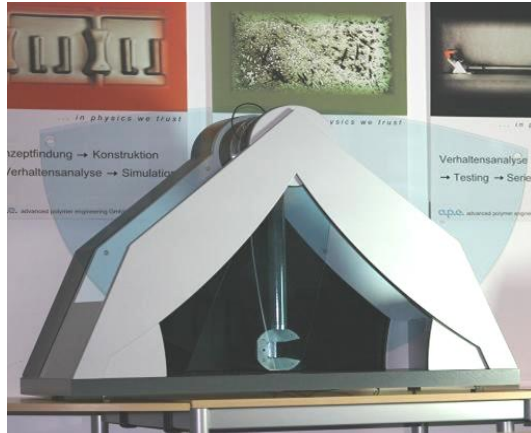

4a impetus Software

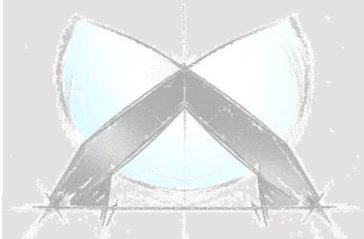
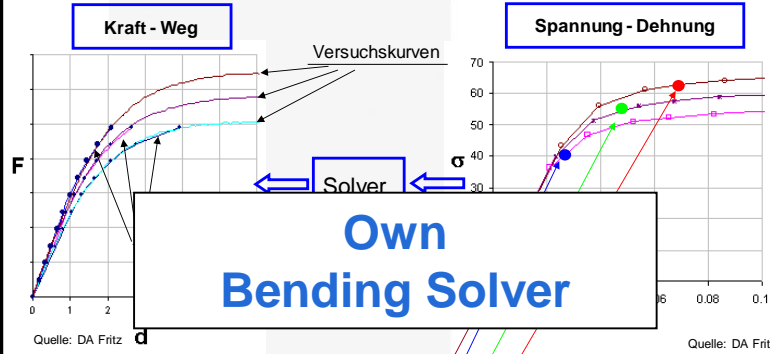
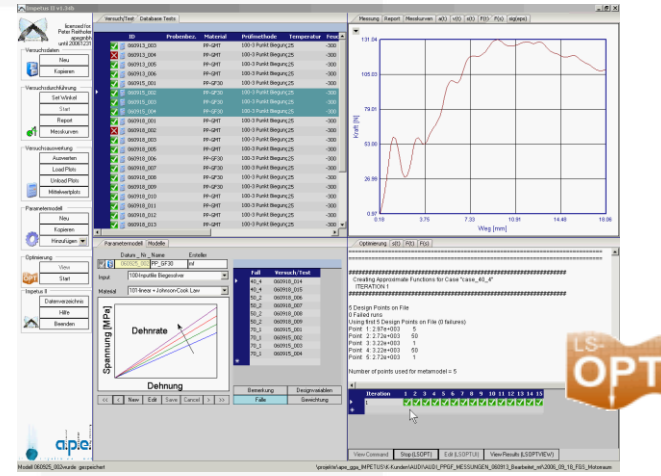

Hardening function

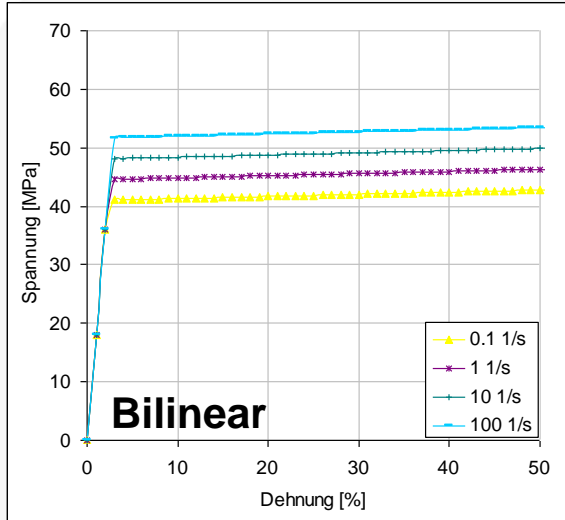

Bending test

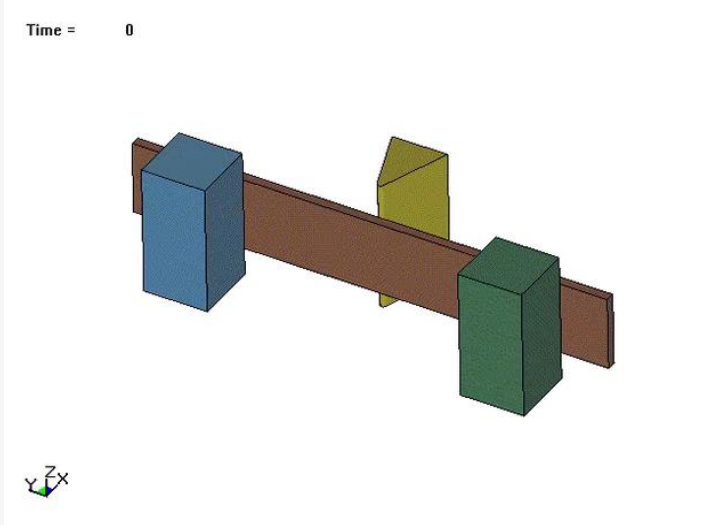
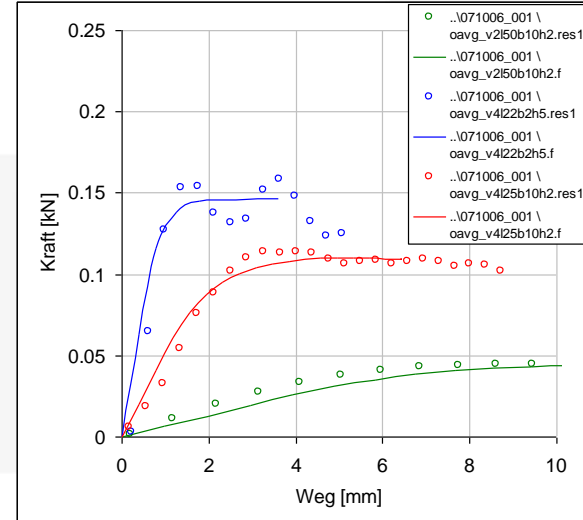
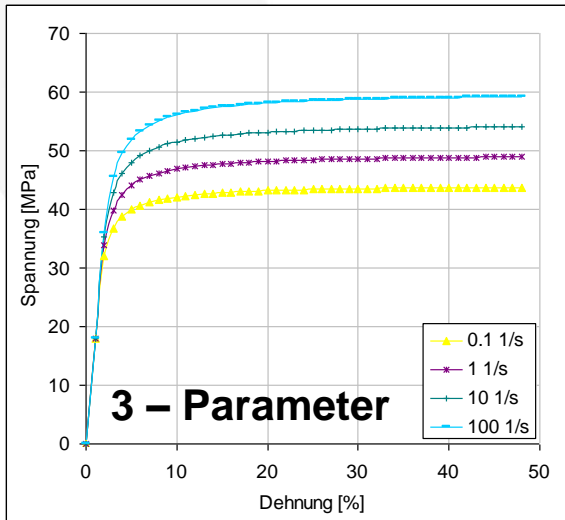
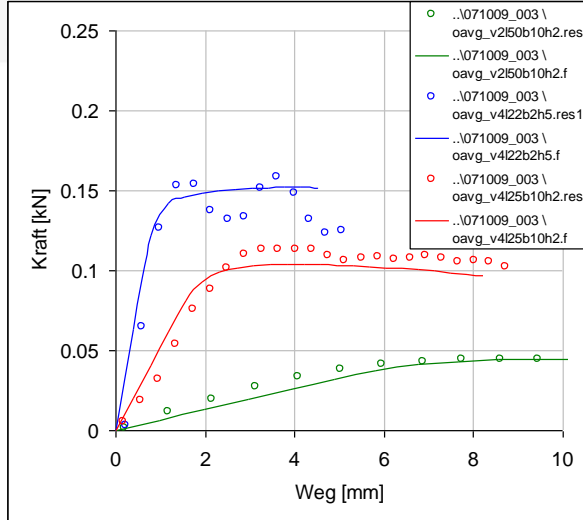

Typical material card
***MAT_024**

applicable
1-100 1/s

Interior / Exterior
drop tests

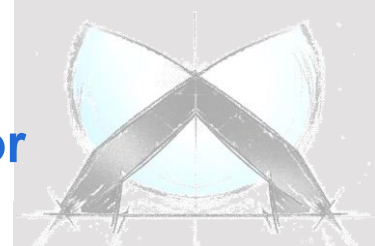

4a impetus Hardware

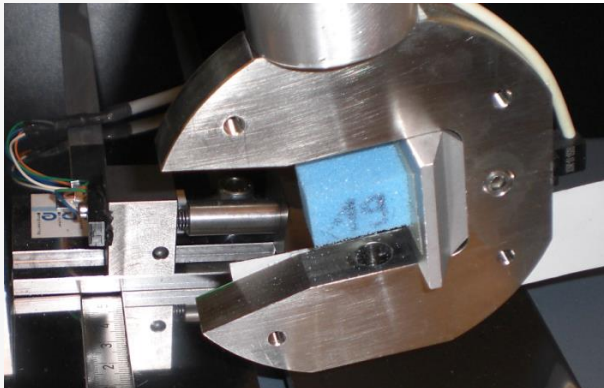
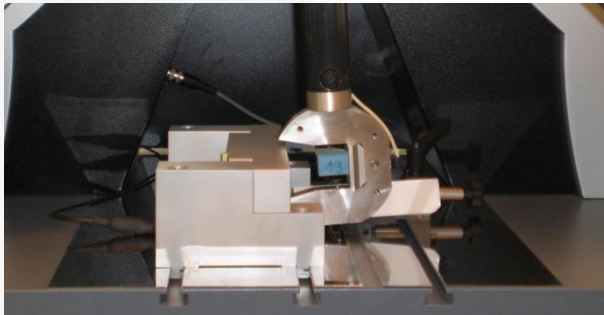

Optical Sensor
impact velocity & detection



4a impetus Software

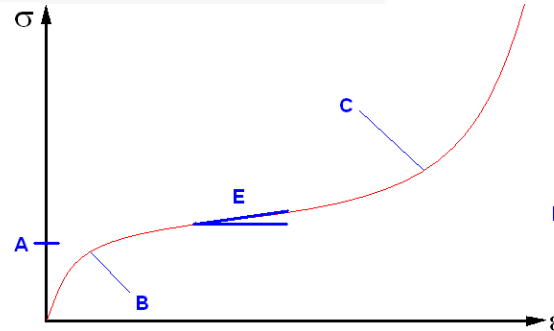

Parameter Identification vs. Neuronal Net

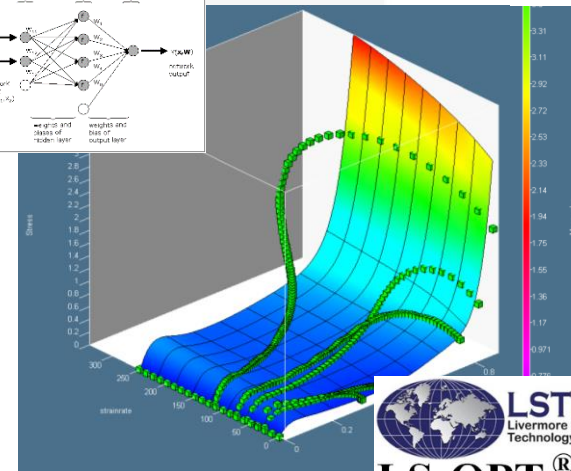
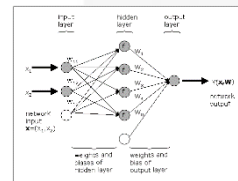

STEP	NO	E	ED	TC	FAIL	GAUGE	TYPE
1	1	1	1	1	1	1	1
2	2	2	2	2	2	2	2
3	3	3	3	3	3	3	3
4	4	4	4	4	4	4	4
5	5	5	5	5	5	5	5
6	6	6	6	6	6	6	6
7	7	7	7	7	7	7	7
8	8	8	8	8	8	8	8
9	9	9	9	9	9	9	9
10	10	10	10	10	10	10	10

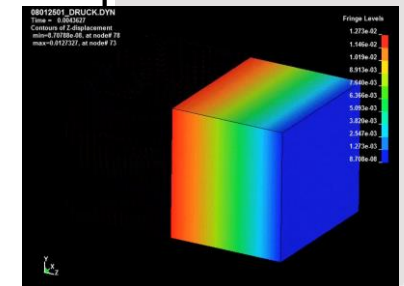
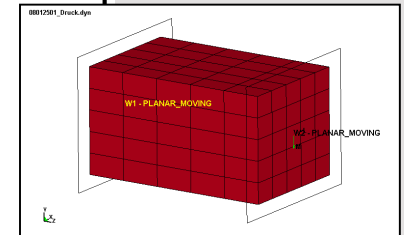

4a impetus Hardware

v	applicable	
m/s	0.001-100 1/s	
4		
2.5	40	510
1	60	1300
0.001	50	

bending setup



Tension loadcase

Fixed bending

4a impetus Software

*MAT_PLASTICITY_COMPRESSION_TENSION

*MAT_SAMP-1

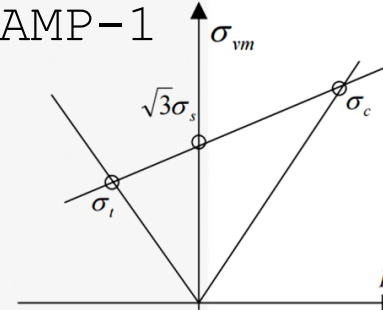

Drucker-Prager [Kolling2005]

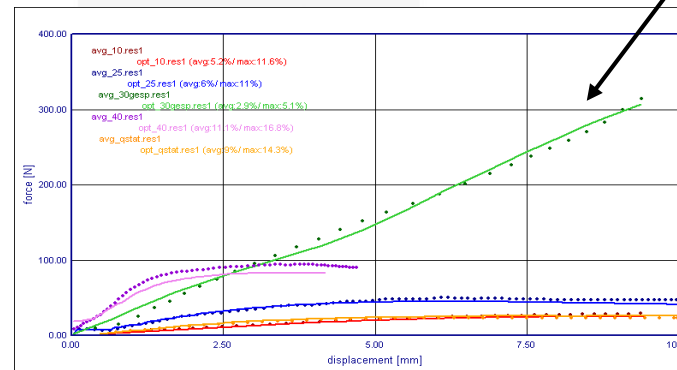
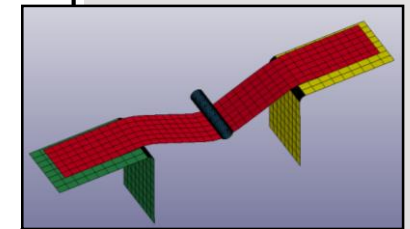

.... averaged test curves
— result of simulation

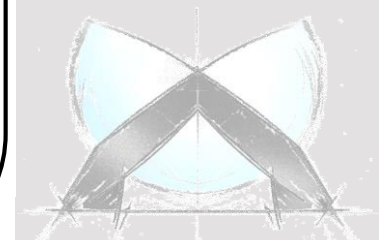

4a impetus Hardware

4a impetus Software



0,01 mm

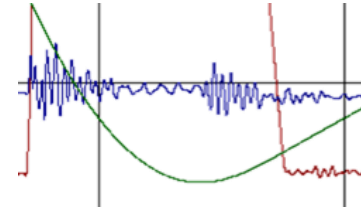
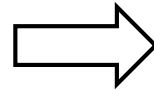
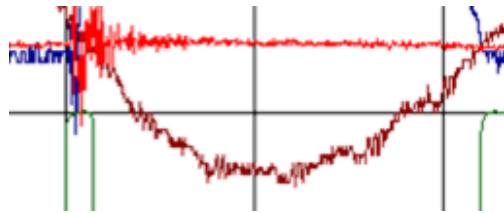

100.000 → 1.000.000 samples/s

Bending 1m/s

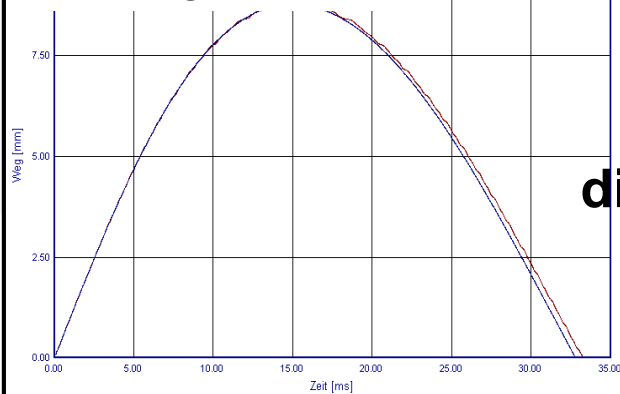

**New
evaluation
velocity,
displacement**

Compression 3.5m/s

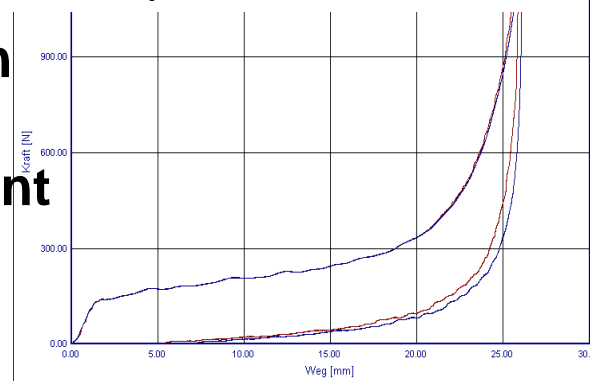

© 4a engineering GmbH, all rights reserved

4a impetus Hardware

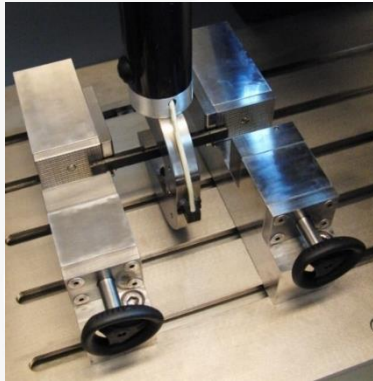

Fixed bending



Component testing

4a impetus Software

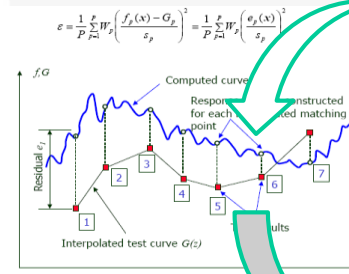

LS DYNAC



Reverse Engineering

- *MAT_024
- *MAT_124
- *MAT_SAMP-1

Hardening Laws

Bilinear

$$\sigma = \sigma_0 + E_T \cdot \epsilon_p$$

G'sell Jonas

$$\sigma = \sigma_0 + K \cdot (1 - e^{-w \cdot \epsilon_p}) \cdot e^{h \cdot \epsilon_p^n}$$

4a three parameter law

$$\sigma = \sigma_0 + E \cdot \epsilon_p \cdot \frac{1}{\left[1 - \frac{E}{H} \cdot \epsilon_p\right]}$$

Strain rate Laws

Cowper Symonds

$$\sigma = \sigma_0(\epsilon) \left[1 + \left(\frac{\dot{\epsilon}}{D} \right)^p \right]$$

Johnson Cook

$$\sigma = \sigma_0(\epsilon) \left[1 + C \ln \frac{\dot{\epsilon}}{\dot{\epsilon}_0} \right]$$

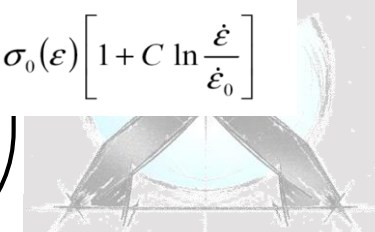

4a impetus Hardware



	*MAT_24 Dynamat	*MAT_187 Dynamat	*MAT_24 Impetus	*MAT_124 Impetus	*MAT_124 Impetus
	base	base	validation	validation	validation
		base			
	validation	base	validation	validation	validation
	validation	validation	base	base	base
				base	
	validation	validation	Validation	validation	base
	validation	validation	validation	validation	validation

classical approach

4a impetus Software

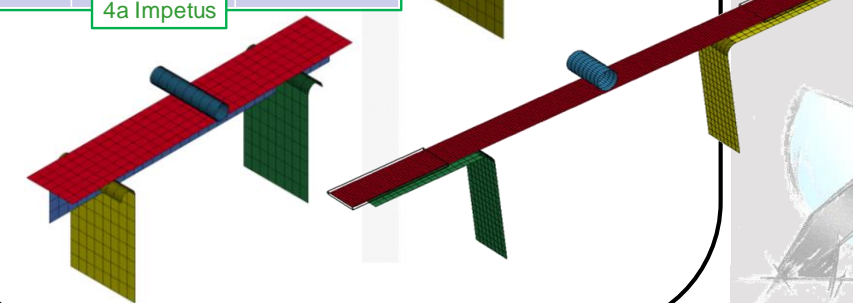
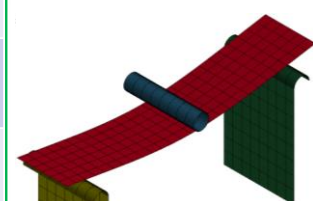
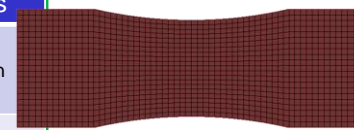

4a Impetus

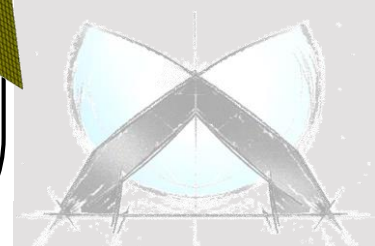
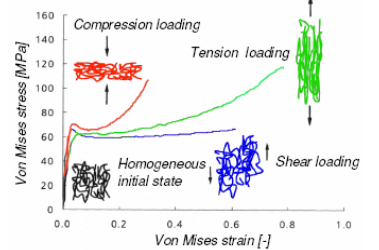
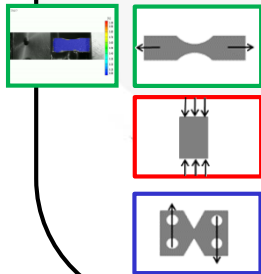

© 4a engineering GmbH, all rights reserved

4a impetus Hardware

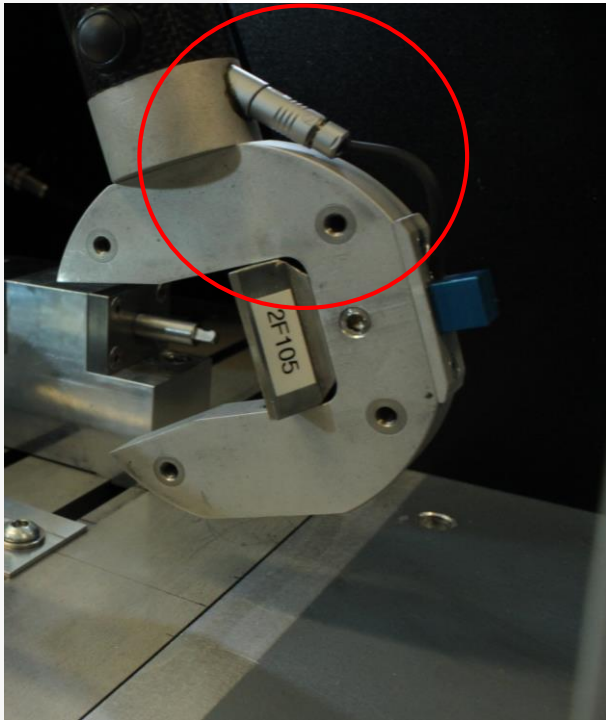

plugable acceleration sensor for pendulum

4a impetus Software

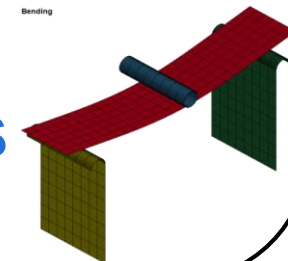
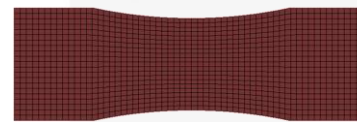
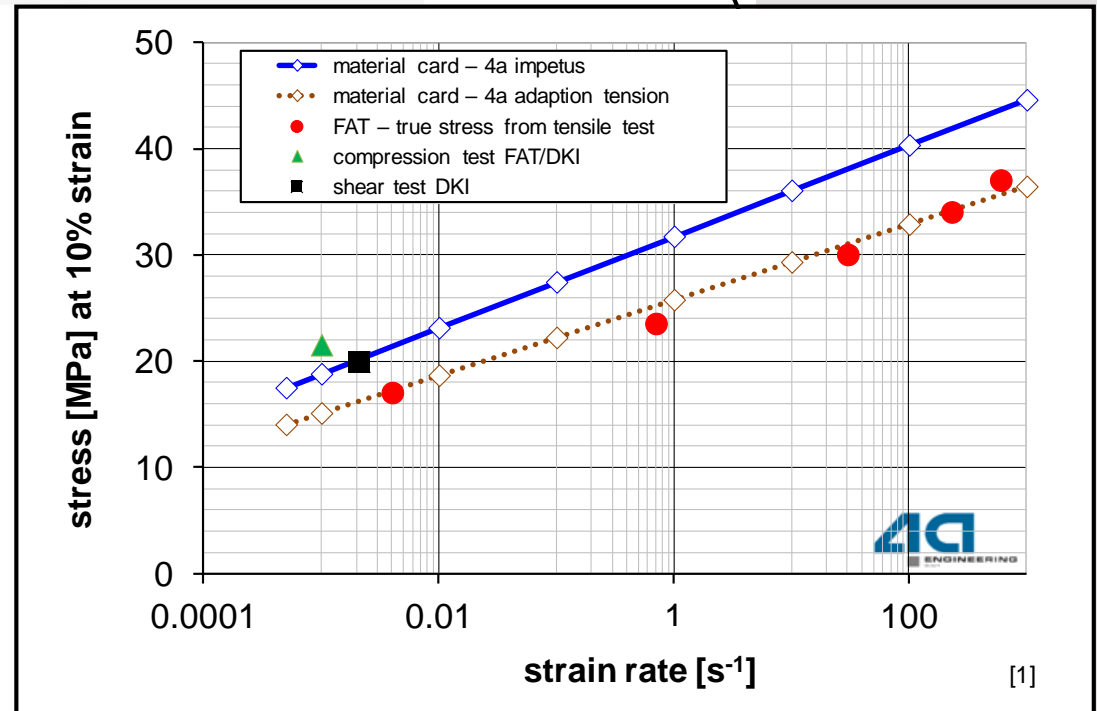

versus

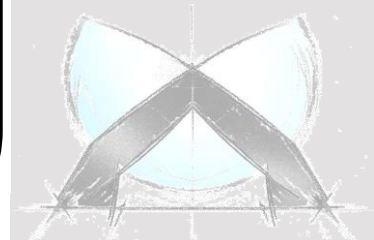

4a impetus Hardware

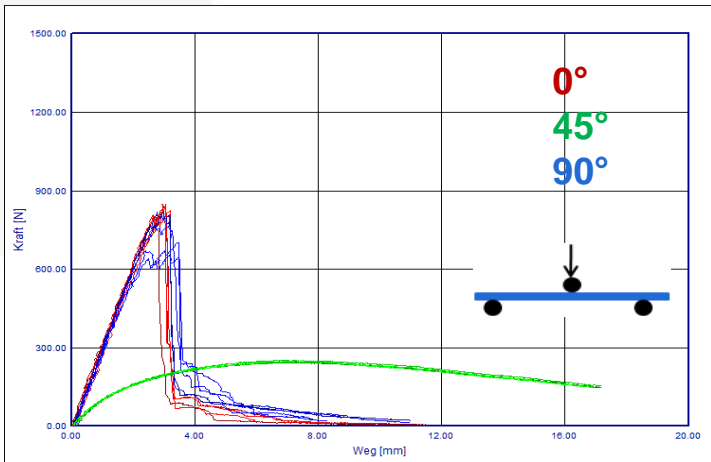
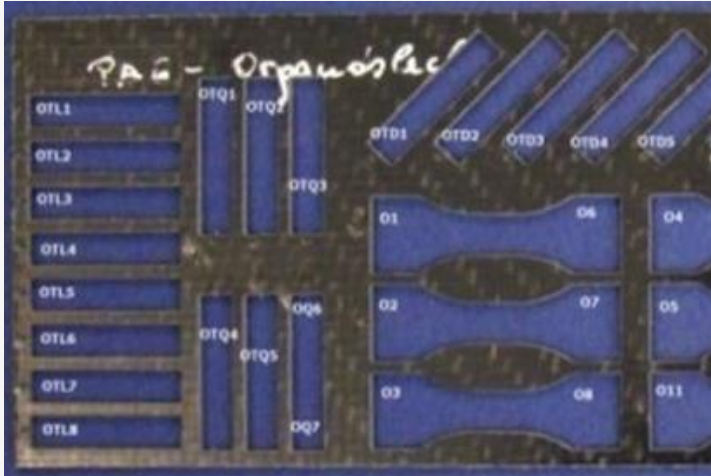

4a impetus Software

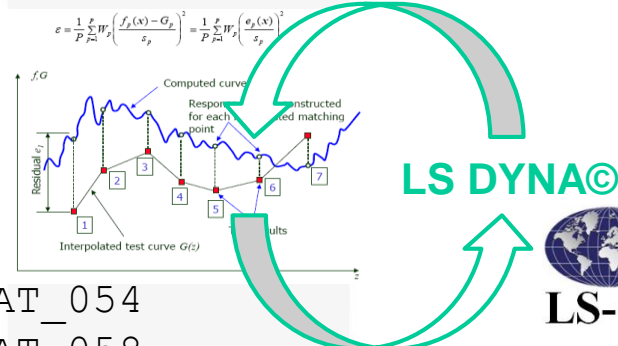

*MAT_054
*MAT_058



Reverse Engineering

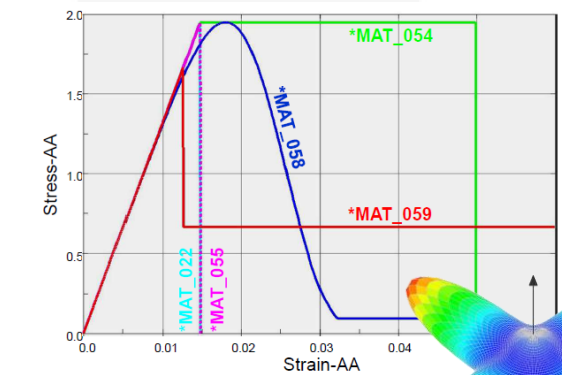

[DYNAmore]

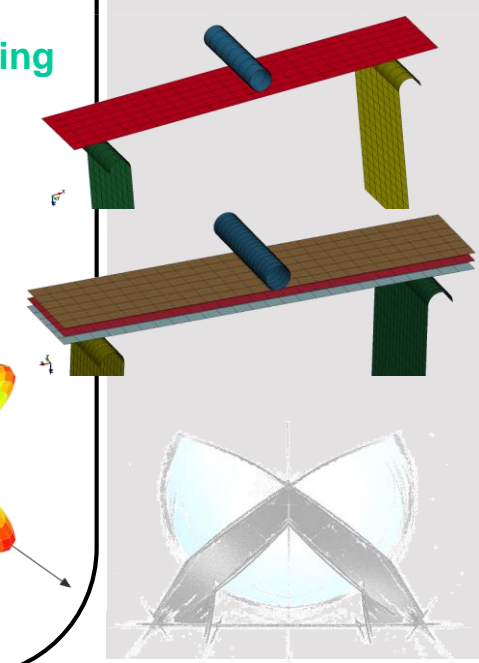

© 4a engineering GmbH, all rights reserved

Dynamic material characterization of plastics

11th LS-DYNA Forum, 2012

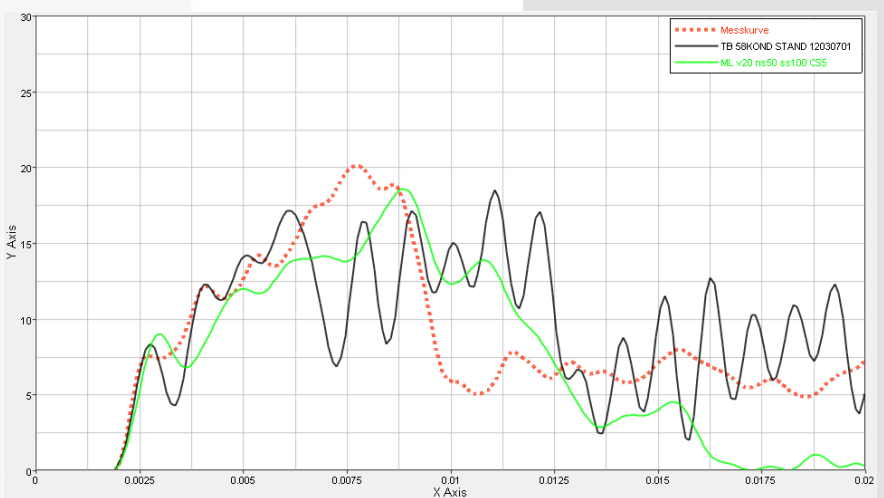
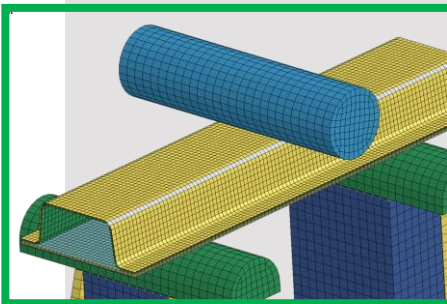
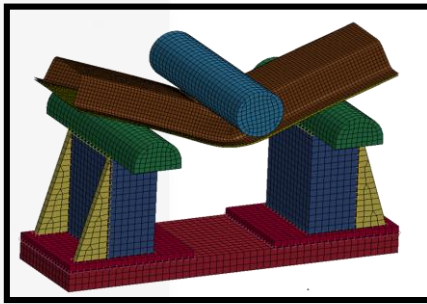
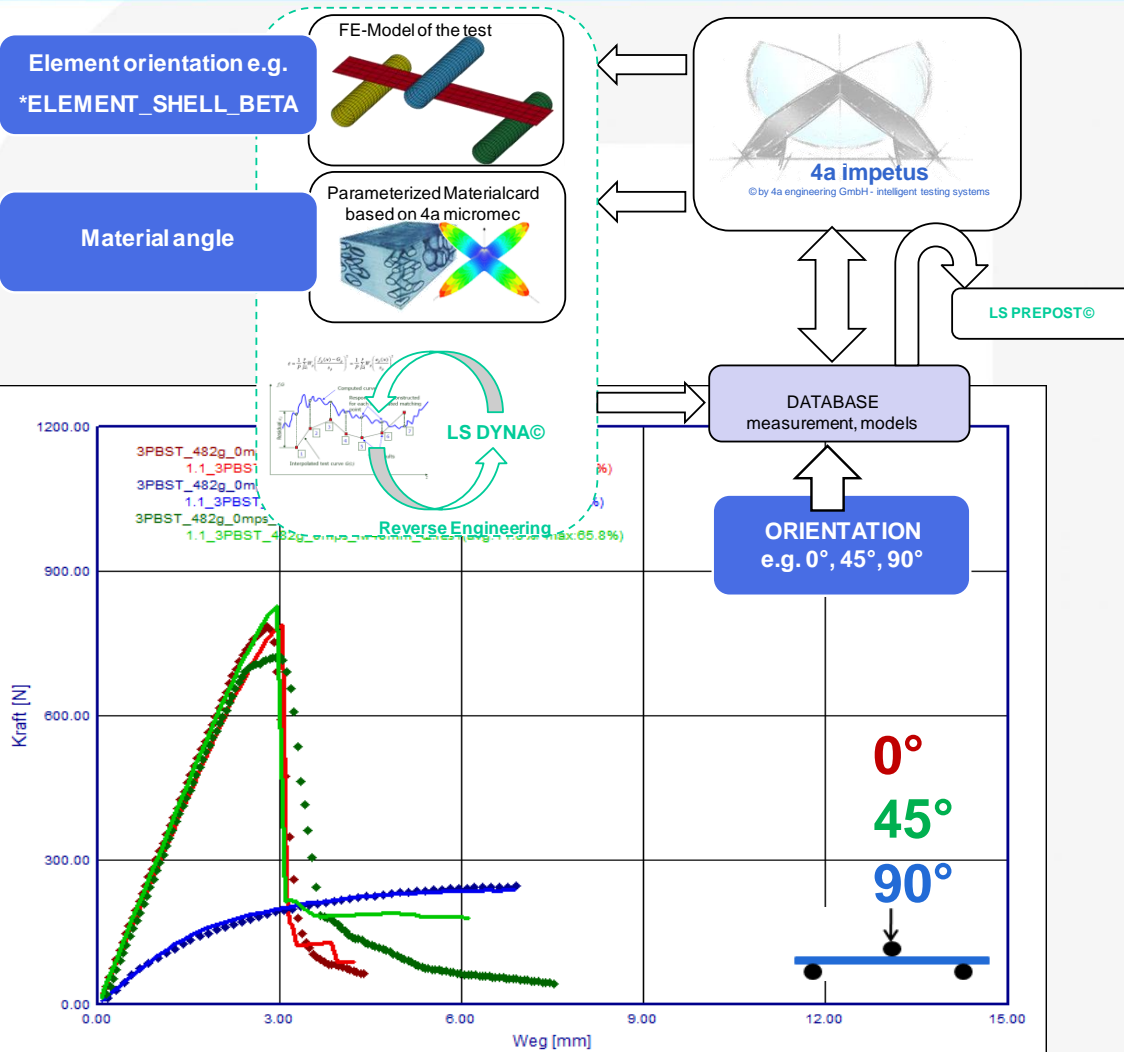

By courtesy of Magna Steyr Engineering Austria



© 4a engineering GmbH, all rights reserved

P. Reithofer - *Dynamische Materialcharakterisierung von Composites mit 4a impetus*, 11. LS-DYNA FORUM, ULM

4a impetus Measurement

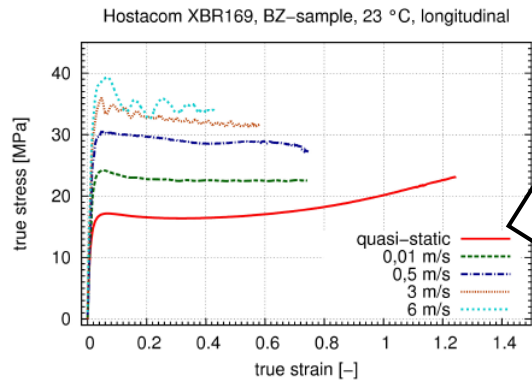

Supported data:

- Zwick ASCII format
- Shimadzu ASCII format
- Plain text
- CSV
- Excel

4a impetus Software

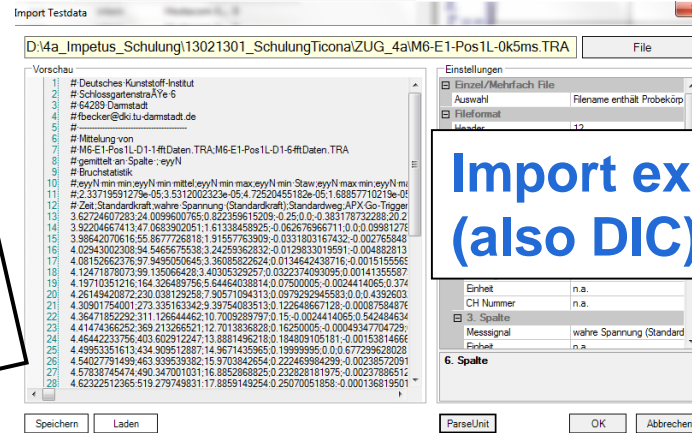

Import external Data (also DIC)

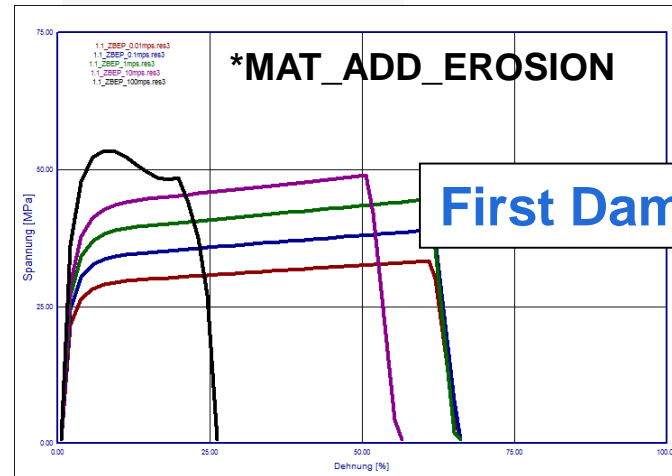

First Damage models

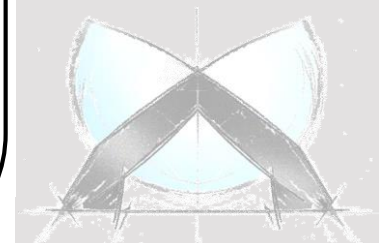

4a impetus Hardware

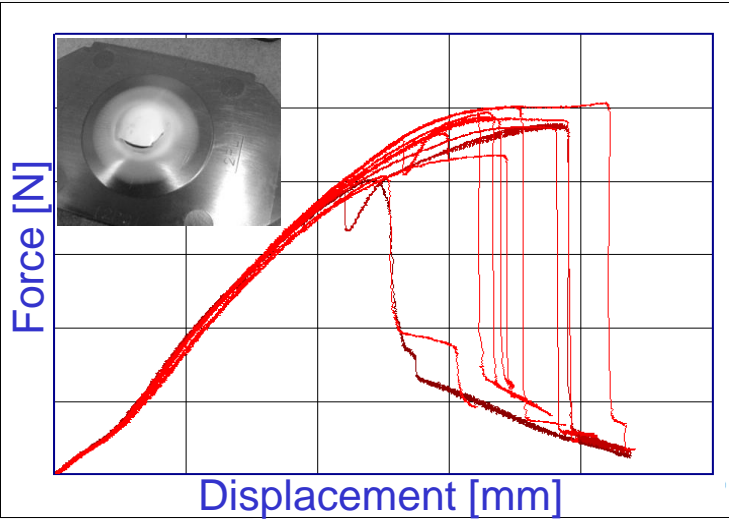

Temperature
(-30°C & 80°C)

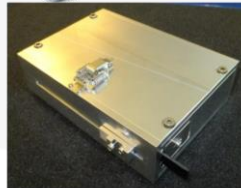
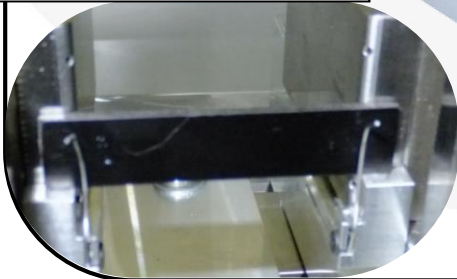

4a impetus Software

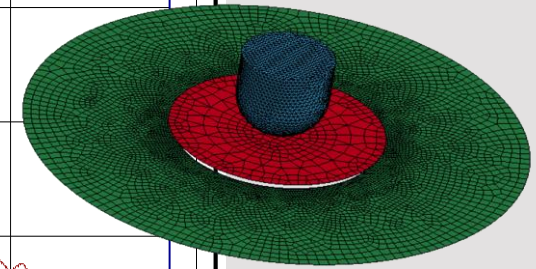
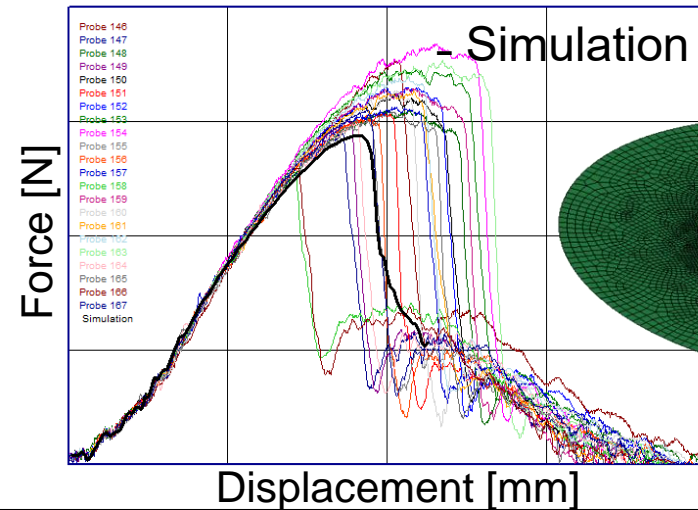

Puncture Test

Statistical methods
→ failure



Dynamic material characterization of plastics

Round Robin Test 2014

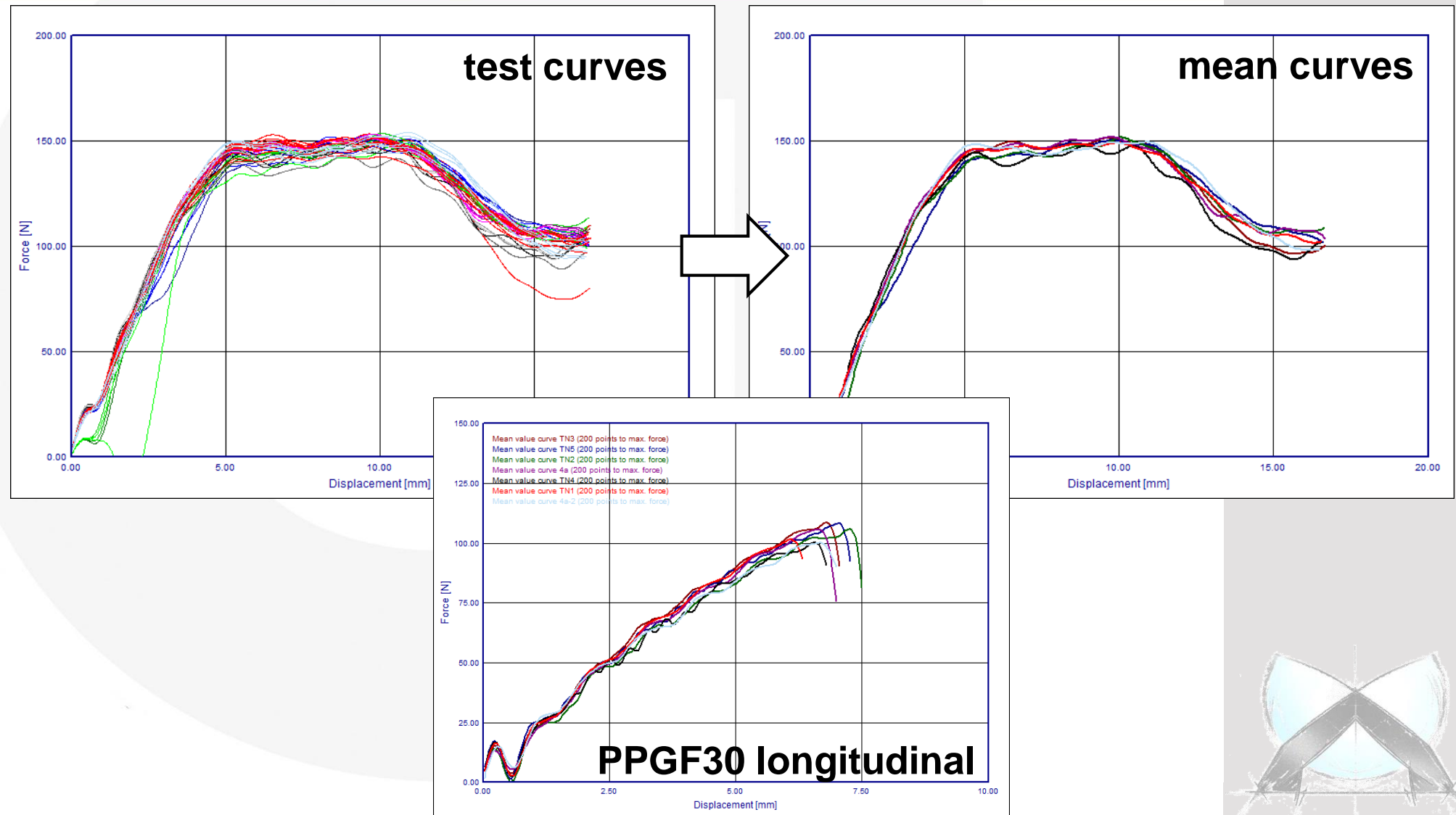

4a impetus Measurement

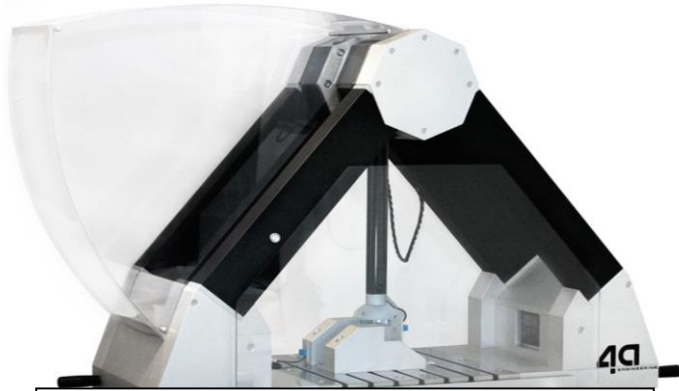

Validation

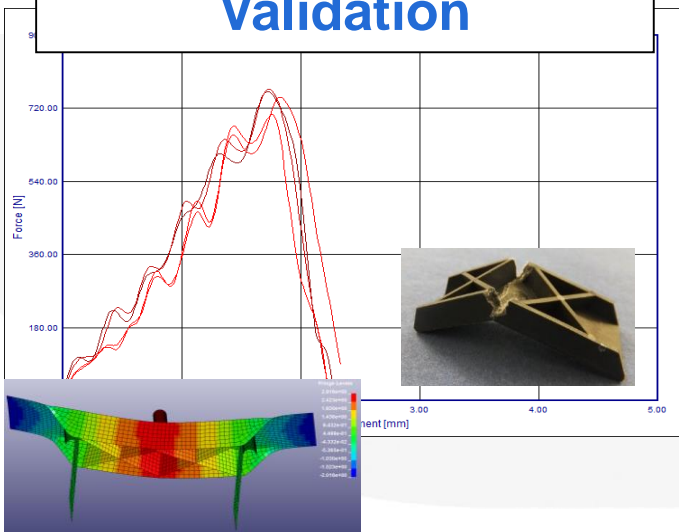

4a impetus Software

Staack, H. et. al: *Application oriented failure modeling and characterization for polymers in automotive pedestrian protection*, 8. Complas, Barcelona 2015

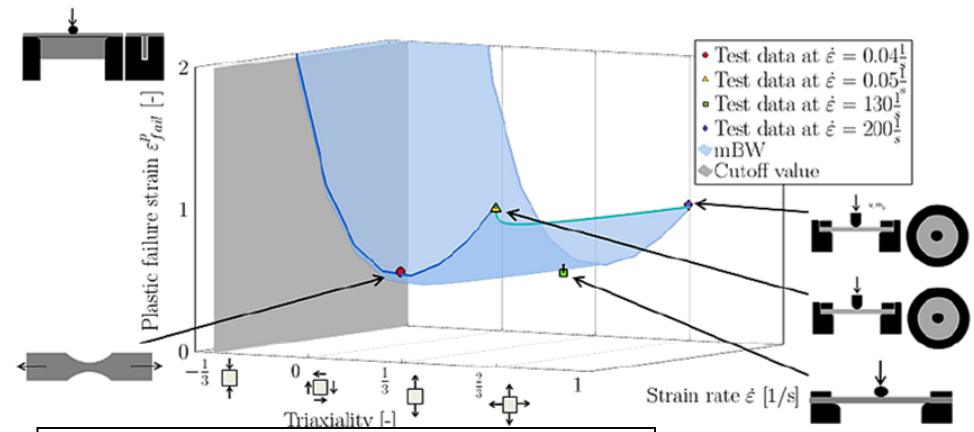

Failure Anisotropy

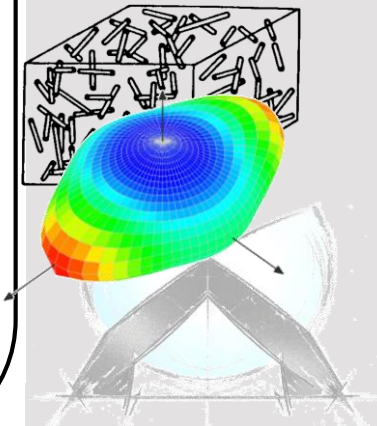
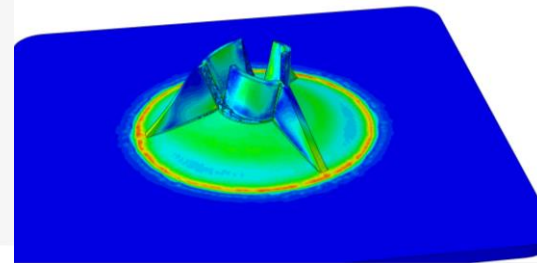

© 4a engineering GmbH, all rights reserved

Dynamic material characterization of plastics

Summary

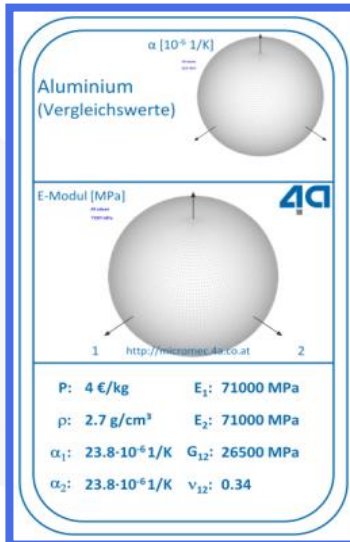
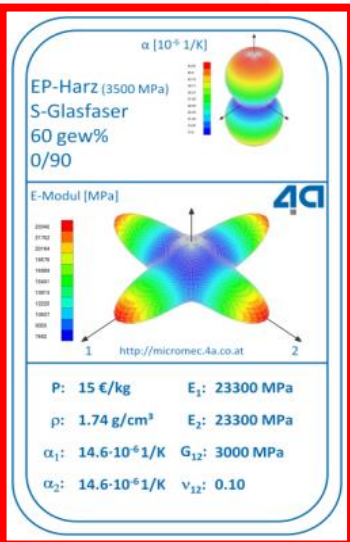
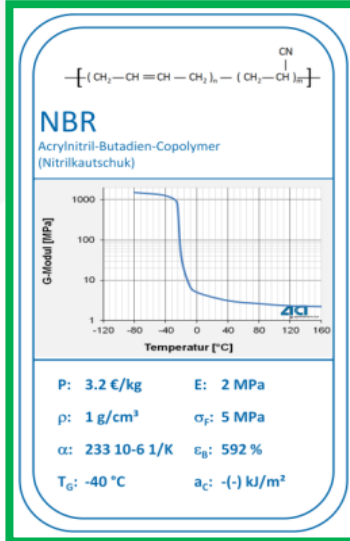
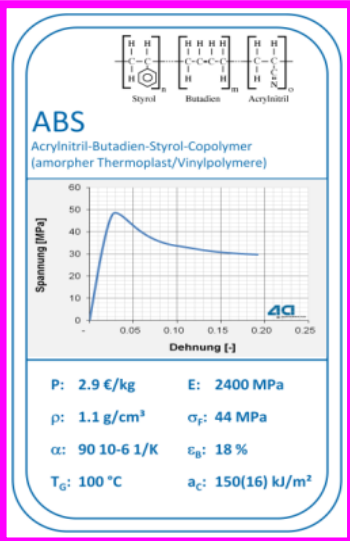

We have already tested a wide range of

- **thermoplastics** (ASA, ABS+PA; ABS+PC; PA6; PA6(6) GF30..50; PA66+P6; PBT GF30; PC; PE; PP; PP+ varnish; PP rubber modified; PP GF20..40; PP Impact modified; PP MX10; PP MX20; PP MX40; PP CF; PP+EPDM; MuCell-materials, ...)
- foams (EPP30..80; PU RG 55, PU RG 65)
- **rubbers** (EPDM, silicone, TPS, ...)
- **thermoset materials** (CFK, GFK with epoxy resin, ...)
- **metals** (aluminum, DC04, ...)
- others
 - fabric (interior, ...)
 - glue (front hood, ...)
 - wood (beech, multiplex, chipboards, MDF)

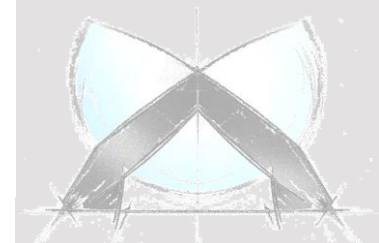

Dynamic material characterization of plastics

Summary

ABS
Acrylnitril-Butadien-Styrol-Copolymer
(amorpher Thermoplast/Vinylpolymere)

Spannung [MPa]

Dehnung []

P: 2.9 €/kg	E: 2400 MPa
ρ: 1.1 g/cm ³	σ _f : 44 MPa
α: 90 10-6 1/K	ε _B : 18 %
T _G : 100 °C	a _c : 150(16) kJ/m ²

NBR
Acrylnitril-Butadien-Copolymer
(Nitrilkautschuk)

G-Modul [MPa]

Temperatur [°C]

P: 3.2 €/kg	E: 2 MPa
ρ: 1 g/cm ³	σ _f : 5 MPa
α: 233 10-6 1/K	ε _B : 592 %
T _G : -40 °C	a _c : (-) kJ/m ²

EP-Harz (3500 MPa)
S-Glasfaser
60 gew%
0/90

E-Modul [MPa]

P: 15 €/kg	E ₁ : 23300 MPa
ρ: 1.74 g/cm ³	E ₂ : 23300 MPa
α ₁ : 14.6·10 ⁻⁶ 1/K	G ₁₂ : 3000 MPa
α ₂ : 14.6·10 ⁻⁶ 1/K	ν ₁₂ : 0.10

Aluminium
(Vergleichswerte)

E-Modul [MPa]

P: 4 €/kg	E ₁ : 71000 MPa
ρ: 2.7 g/cm ³	E ₂ : 71000 MPa
α ₁ : 23.8·10 ⁻⁶ 1/K	G ₁₂ : 26500 MPa
α ₂ : 23.8·10 ⁻⁶ 1/K	ν ₁₂ : 0.34

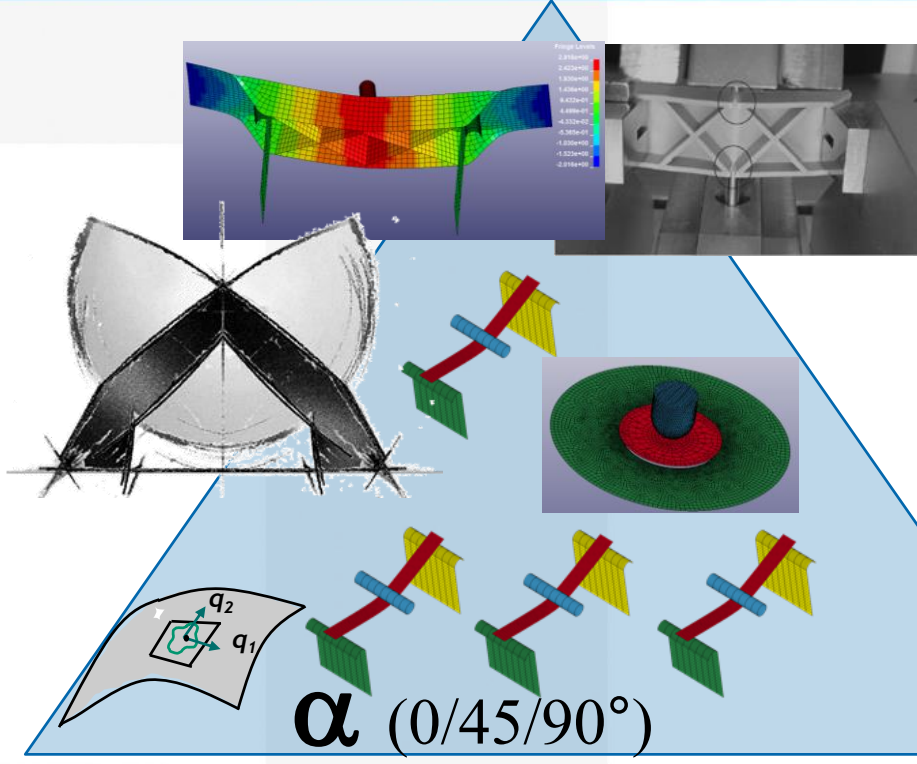

component validation

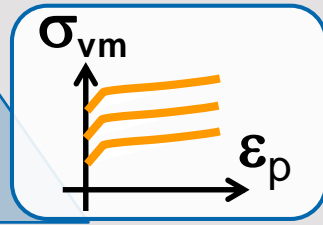
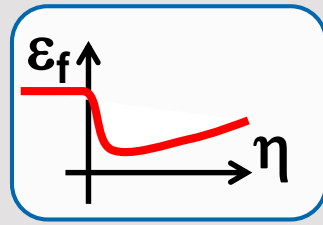

Workflows
validated material card

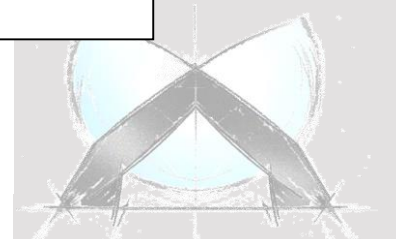

Thank you for your attention!

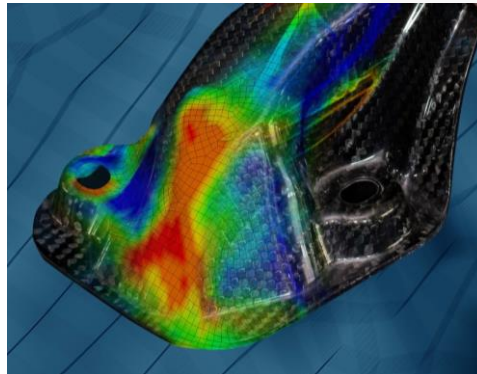

14th **4a**
TECHNOLOGIETAG

23.- 24. March 2017
in Schladming, Austria

„Light weight applications & Composites”
More information: <http://technologietag.4a.co.at/>

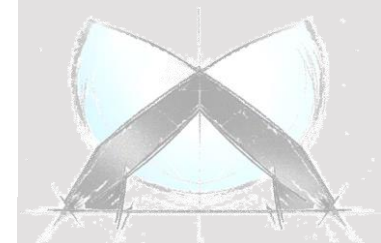

© 4a engineering GmbH, all rights reserved