

Recent Developments in LS-DYNA

Dr. John Hallquist

LSTC

Summary:

In this presentation Dr. John O. Hallquist, founder and president of Livermore Software Technology Corporation (LSTC), will give an overview about recent developments in LS-DYNA.

LS-DYNA is a highly advanced general-purpose nonlinear finite element program that is capable of simulating complex real world problems. The distributed memory solver provides very short turnaround times on Unix, Linux and Windows clusters. The major development goal of LSTC is to provide within LS-DYNA capabilities to seamlessly solve problems that require

- **"MULTI-PHYSICS"**,
- **"MULTIPLE STAGES"**,
- **"MULTI-PROCESSING"**.

Its fully automated contact analysis capabilities and error-checking features have enabled users worldwide to solve successfully many complex crash and forming problems. LSTC develops sophisticated tools for modeling and simulating the large deformation behavior of structures. In addition to LS-DYNA the tools LS-PREPOST for pre - and post-processing, and LS-OPT for optimization are developed by LSTC.

The main applications are:

- Large Deformation Dynamics and complex Contact Simulations
- Crashworthiness Simulation
- Occupant Safety Systems
- Metal Forming
- Explicit/ Implicit Analysis
- Metal, Glass, and Plastics Forming
- Multi-physics Coupling
- Failure Analysis
- Sophisticated Material Models
- Fluid-Structure Interaction
- SPH (Smooth Particle Hydrodynamics)
- EFG (Element Free Galerkin)

LSTC was founded in 1987 by John O. Hallquist to commercialize as LS-DYNA the public domain code that originated as DYNA3D. DYNA3D was developed at the Lawrence Livermore National Laboratory, by LSTC's founder, John O. Hallquist.

Livermore Software Technology Corporation
7374 Las Positas Road,
Livermore, CA, 94551, USA

<http://www.lstc.com>

Recent Developments in LS-DYNA®

7th European LS-DYNA Conference

J.O. Hallquist

May 14-15, 2009



1

Outline of talk

- Part I
 - Introduction
 - LSTC dummy/barrier developments
 - Hybrid LS-DYNA
- Part II
 - Implicit update
 - Version 971 release 4 and later
 - Version 980
 - Conclusions



2

LSTC

- Five products:
 - LS-DYNA
 - LS-OPT, LS-OPT/Topology
 - LS-PrePost
 - FE Models: Dummies, barriers, head forms
 - USA (Underwater Shock Analysis)
- LS-PrePost[®], LS-OPT[®], the FE models and are part of the LS-DYNA[®] distribution and do not require license keys.



3

Underwater Shock Analysis

- LSTC completed purchased of USA with all intellectual rights in 2007.
- USA is embedded within a special version of the 971 release
 - Export controlled under ITAR
- Offer “non-conformal” Doubly Asymptotic Approximation (DAA) elements
- Cavitating Acoustic Spectral Element replace the type 8 acoustic solid elements
 - Also released with the 971 version as an executable separate from theDAA solver



4

LS-DYNA/USA example

MAT_ACOUSTIC
for surrounding
water

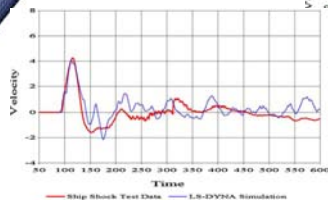
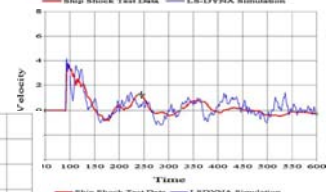
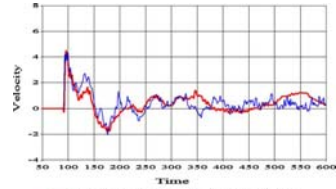
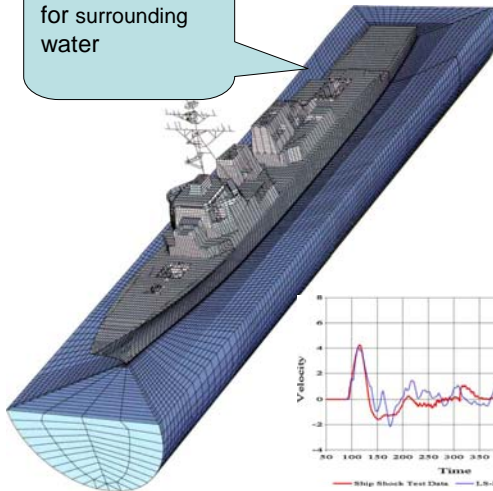

Y. Shih, Ship shock modeling and simulation for far-field underwater explosion
Computers and Structures 82 (2004) 2211–2219

5

Applications of LS-DYNA

- Automotive
 - Crash and safety
 - Durability
 - NVH
- Aerospace
 - Bird strike
 - Containment
 - Crash
- Manufacturing
 - Stamping
 - Forging
- Structural
 - Earthquake safety
 - Concrete structures
 - Homeland security
- Electronics
 - Drop analysis
 - Package design
 - Thermal
- Defense
 - Weapon design
 - Blast response
 - Penetration
 - Underwater shock analysis
- Consumer products



6

One code strategy

Combine the multi-physics capabilities

- Explicit/Implicit solver
- Heat Transfer
- ALE
- EFG, SPH, Airbag particle method
- Incompressible fluids (version 980)
- CESE compressible fluid solver (version 980)
- Electromagnetics (version 980)
- Acoustics
- Interfaces for users, i.e., elements, materials, loads

into one **scalable** code for solving highly nonlinear transient problems to enable the solution of coupled multi-physics and multi-stage problems.



7

Development goals

- Reduce customer costs to encourage and enable massively parallel processing for large scale numerical simulations
 - Multicore processors have resulted in a drastic reduction in computer hardware costs and a huge increase in LS-DYNA licenses worldwide
 - Approaches used by LSTC to help reduce costs:
 - Flexibility: 4 core license allows 4 one core jobs or one 4 core job.
 - Unlimited core site license
 - Steeply decreasing licensing fees per core as the number of processors increase



8

Development goals

- Further reduce customer costs by increasing computational speed and improving scalability
 - By continuously recoding existing algorithms and developing new more efficient methodologies
 - Ensuring that LS-DYNA is fast, accurate, robust, and the most scalable software available
- And help reduce costs by providing FEA models and necessary peripheral software
 - LS-DYNA dummy, headform, and barrier models
 - LS-DYNA dedicated pre and post processing software
 - LS-DYNA specific optimization software



9

Ultimate development goal

- Simulation results accepted in place of prototype testing
 - What is required?
 - Continued software improvements in LS-DYNA
 - Implicit-explicit compatibility and robustness
 - Constitutive models
 - Contact
 - FSI with SPH, ALE, Particle methods, etc.
 - Sensors and control systems
 - Improved element technology
 - Manufacturing simulations providing the initial geometry, with stress and strain distributions
 - Massively Parallel Computing with scaling to 1000's of nodes for implicit and explicit solvers.



10

Dummy/barrier developments

Dummy models under development

- EuroSID 2re
- Hybrid III 3-year old
- Hybrid III 6-year old
- SID-IIs D Rigid-FE
- Hybrid III 5th percentile female
- NCAC is beginning work on the Hybrid III 95th percentile male
 - LSTC funded.

Dummy distribution

- For licensed LS-DYNA users
 - No separate licensing from LS-DYNA
- Feedback on dummy performance is welcome but not required.
 - Feedback will be used to improve future releases
- No encryption
- Continuous dummy update and support is provided by LSTC and LS-DYNA distributors
- The dummies generated by LSTC use Truegrid® parametric meshing



13

Update EuroSID 2re

Joint Development with DYNAmore

- Meshing completed
- Model build-up completed
- Some certification tests finished

Ongoing:

- Material adjustments
- Validation tests

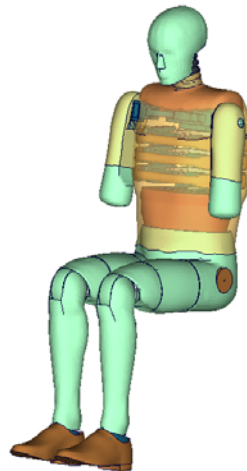

14

Update EuroSID 2re

Joint Development with DYNAmore

- Tests used for validation.

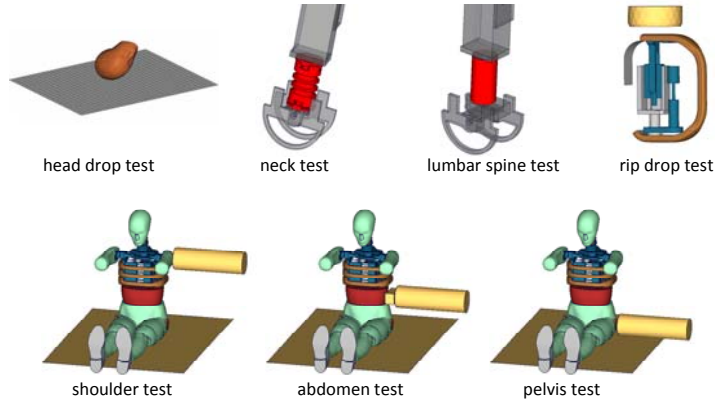

Update Hybrid III 3-year-old

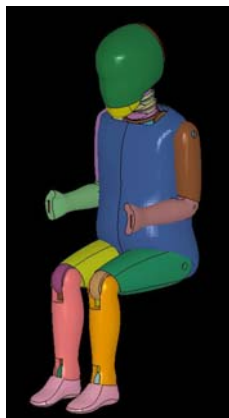

- Mesh almost completed

Coming soon:

- Build-up of the model
- Gathering of certification test data
- Material adjustments
- Certification test setup

Update Hybrid III 6-year-old

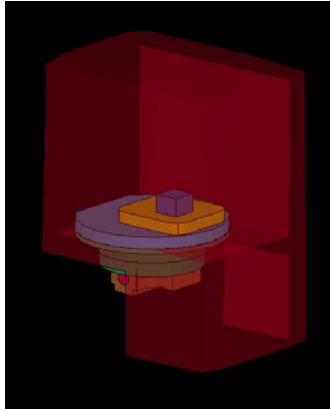

- Meshing of mechanical and interior components initialized
- Surface data received

Ongoing:

- Meshing

Update SID-IIs D Rigid-FE

- Fast turn around time
- Meshing completed
- Model buildup completed

Ongoing:

- Material and part response adjustments
- Validation tests



Update Hybrid III 5th percentile female

Joint Development with NCAC

- Meshing completed
- Model buildup completed
- Initial simulations completed
- LSTC release planned later this year

Ongoing:

- Test for robustness
- Validation tests



19

Available LSTC Dummy Models

- SID-II
 - Hybrid III 50th percentile FE
 - Hybrid III Rigid-FE Adults
 - USSID
- All available models can be obtained through LSTC's ftp site: <http://ftp.lstc.com/user/>
 - Feedback about performance and suggestions about further improvements should be sent to: atds@lstc.com



20

Update SID-IIs D

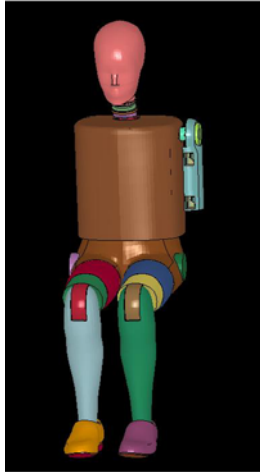

- Validation of initial model with adjusted material properties completed
- First BETA testing completed
- Initial customer feedback incorporated
- Model stability and response improved
- Released to all customers
- ~300000 nodes and elements.

Coming soon:

- Incorporation of material test results into model

Detailed sectional views

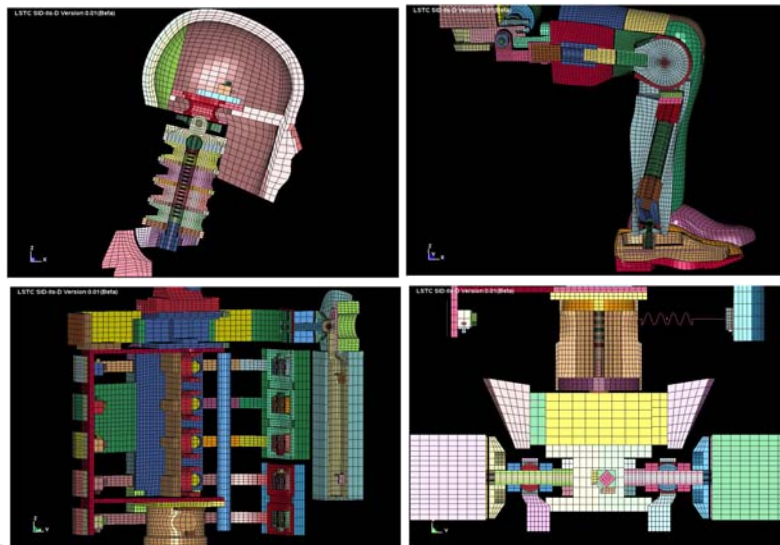

Update Hybrid III 50th

Joint Development with NCAC



- Validation of initial model with adjusted material properties completed
- Model stability and response improved
- Alpha Version released to all customers

Coming soon:

- Incorporation of material test results into model

Update Hybrid III 50th

- The Dummy Time-Step is exactly 0.5 Microseconds, with an Added Mass of 50-grams.
- Size: 228,000 Nodes and 256,000 Elements
- Computation Time for the Sled Model shown to 150ms:
 - 3-hours 20-minutes using 16-cpus
 - 2-hours 10-minutes using 32-cpus
- Material Models will change after Material Testing is complete
- The Dummy can be easily positioned in LSPP using much of the same methods we established for the previous Rigid_FE Dummy.
- We will continue to investigate correlations to known Test Results

Update Hybrid III 50th

Driver-Belt Template With Load_Loading
View =



Driver-Belt Template With Load_Loading
View =



25

Update Hybrid III Rigid-FE Adults

- Model stability and response improved
- Customer feedback incorporated
- Further improvements planned

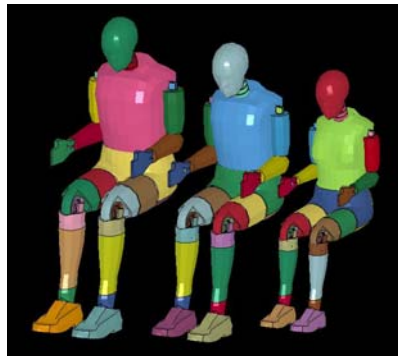

26

Update USSID

Originally developed for KIA Motors based on NHTSA public domain version of USSID

Major enhancements include:

- Improved discretization for jacket, arm, pelvis
- Improved material data for foams
- One global contact

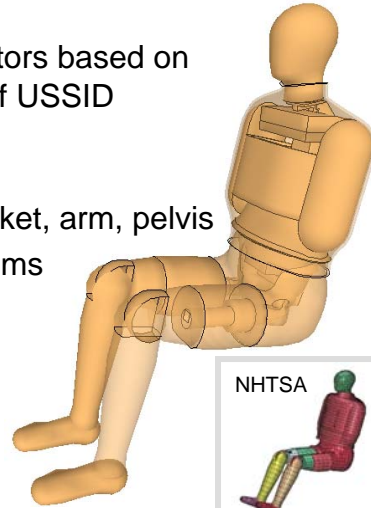

Free Motion Headform

- The headform was meshed using TrueGrid® based on NHTSA design drawings and outer surface scan data provided by an automotive supplier.
- The center of gravity (CG) , the total mass, and inertia are within the tolerances specified in the NHTSA
- Material constants are based on experimental test dated.
- The unit system used is *mm-ms-kg-kN*
- To obtain model or to make suggestions contact dilip at: dilip@lstc.com.

FMH Correlation

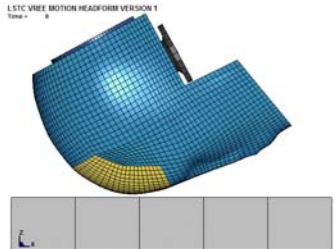

Response	Test / Spec	FEA
Peak Resultant Accel, Gs (2.72m/s)	225 to 275	266
Peak Lateral Accel, Gs (2.72/ms)	-15 to 15	-5.71
Peak Resultant Accel, Gs (4.02m/s)	437	449
Peak Resultant Accel, Gs (6.71m/s)	1067	1031
Total Mass, kg	4.54 ± 0.05	4.58



LSTC family of barriers

- Frontal offset barrier
 - Solid
 - Meshless (EFG)
 - Shells
- MDB (FMVSS 214)
 - Solid
 - Shell
- SICE (IIHS)
 - Solid
 - Shell
- ECE Rev 95
 - Shell



LSTC family of barriers

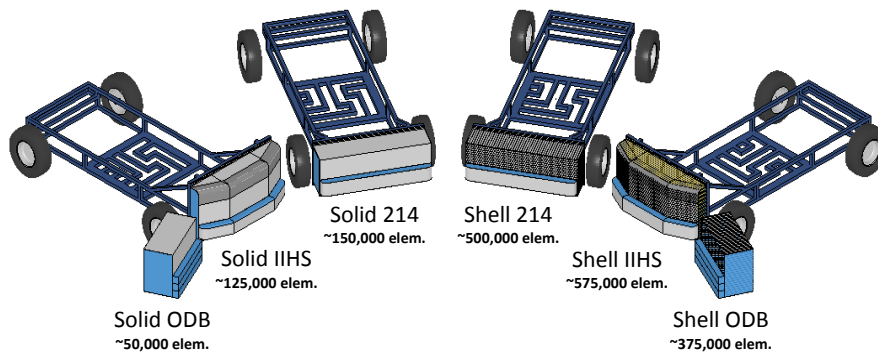

LSTC ODB Status Update

- Development based on 16 available OEM Tests
- Both Shell and Solid Version show promising results
- Solid version used to perform DOE (200+ runs) to study sensitivity of some important variables such as honeycomb shear damage, adhesive failure strength, cladding failure , etc.
- Verification runs made to reduce overall MSError compared to test

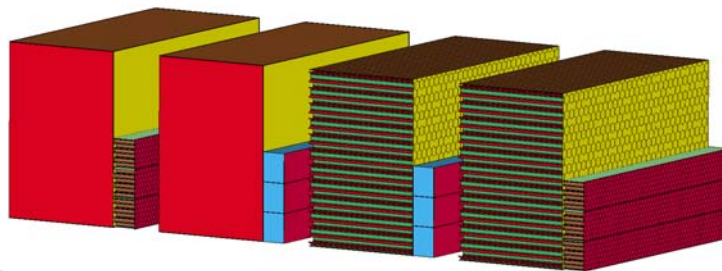

Solid Results

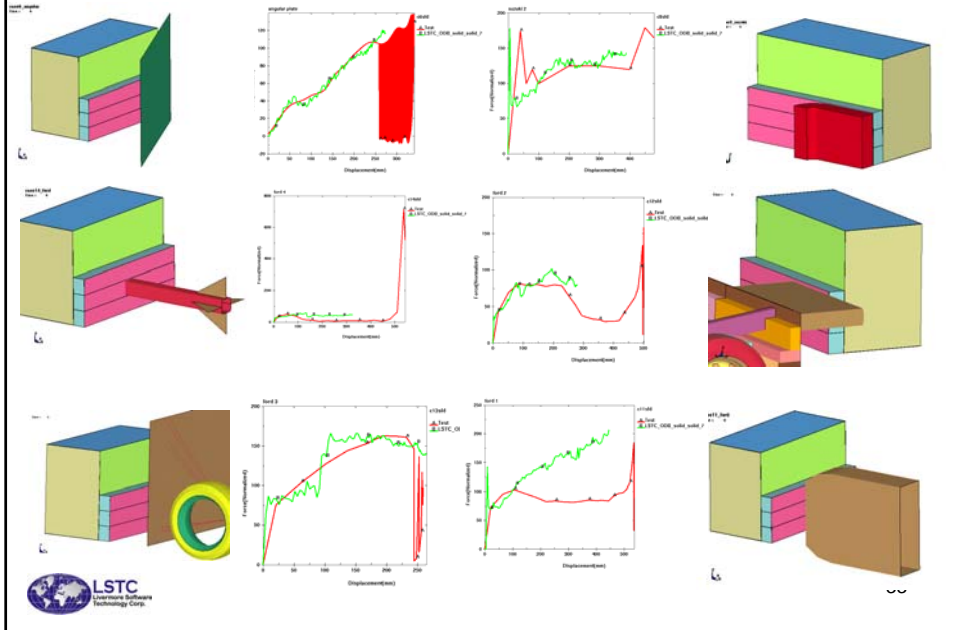

Shell Results

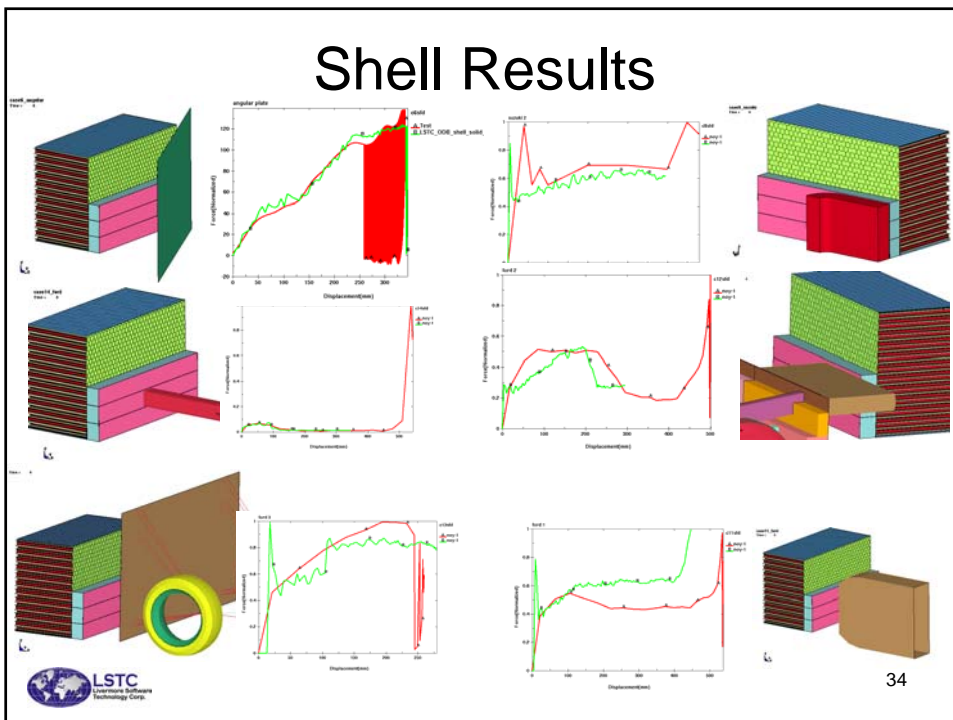

Remarks

- Current shell and solid ODB barriers are production ready and will be released shortly with documentation for public use
- Solid barrier takes roughly 10 minutes while the shell barrier takes 4 hours
- Future planned development includes but not limited to:
 - Fine-tuning correlation for certain load-cases
 - Adhesive area is better represented in shells. This approach will be incorporated in solids by using shells to model honeycomb at the cladding interface
 - Improve Predictive Robustness using LS-OPT to eliminate sensitivity on intrusion numbers
- We thank all the OEMs who provided us with the test data and helped us in “beta” evaluation

ECE Rev 95

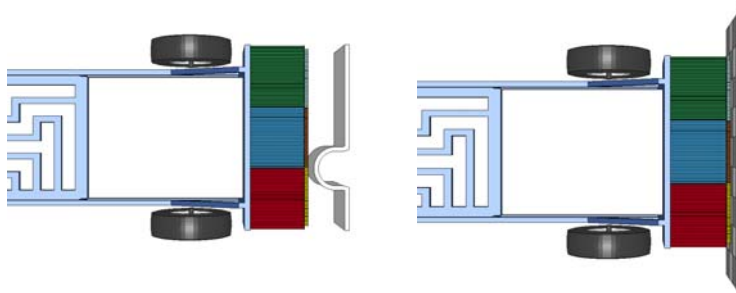

Pole Impact Setup

Flat wall Impact Setup

ECE Rev 95 version 1

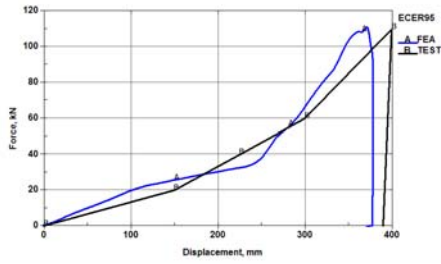

Pole impact

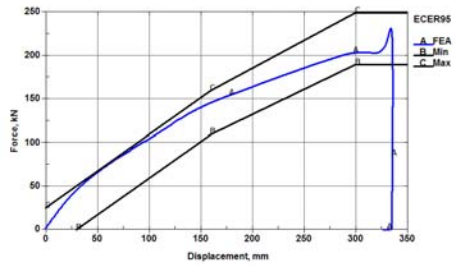

Flat wall impact



ECE Rev 95 version 2

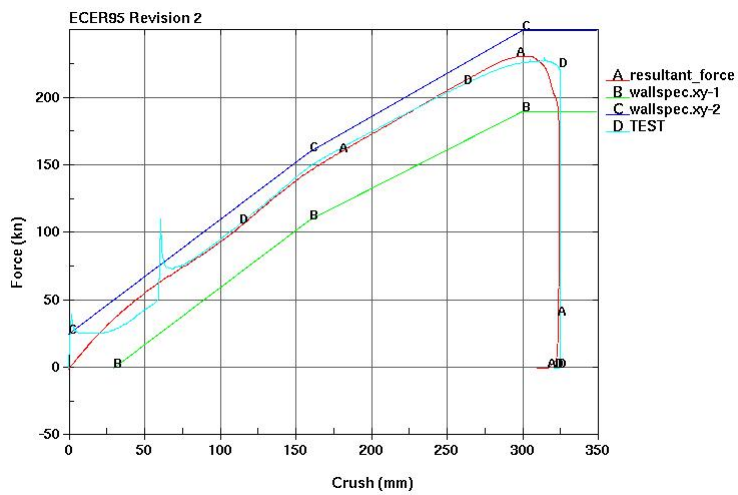

Side impact barrier status

- LSTC_214_SOLID_BARRIER.102408_V3.0
- LSTC_IIHS_SOLID_BARRIER.102408_V3.0
 - Honeycomb material coordinate system now defined using –AOPT
 - This will make the positioning easy for the user.
 - 971 R3.2.1 or newer required
- Version 2.0 of ECE Rev 95 side impact barrier will be released soon
 - Addition of airbags and venting of trapped air
 - Improved match with experimental results
- LSTC_214_SHELL_BARRIER
 - 7 additional tests cases will be added for barrier validation
 - Next release will be validated to more tests
- UNITS
 - All LSTC barriers use the *mm-ms-kg-kN* unit system. Unit system conversion can be done by the *INCLUDE_TRANSFORM keyword.
- Contact Dilip at dilip@lstc.com for more information

Hybrid LS-DYNA

Hybrid mpi/smp

- Historically, LS-DYNA source code supports both OpenMP and MPI.
 - OpenMP directives are ignored in the MPI version
- A hybrid MPI version is now being tested using the OpenMP directives
 - Use MPI between multi-core nodes and shared memory OpenMP within the nodes.
 - Avoids the extra communication overhead with MPI within a node
 - Open SMP usage leads to larger message sizes, thereby achieving better load balancing as the number of nodes increase.
 - Most LS-DYNA problems have two-level parallelism naturally.

Hybrid mpi/smp

- LSTC is working with Intel in the development of a hybrid version of LS-DYNA
- The hybrid version is observed to scale better and run faster for large models than the MPI-only version on more than 256 cores.
- Consistency is maintained, i.e., identical answers on repeated runs with the same domain decomposition using 1, 2, 4, and 8 cores per node with Open SMP.

Consistency

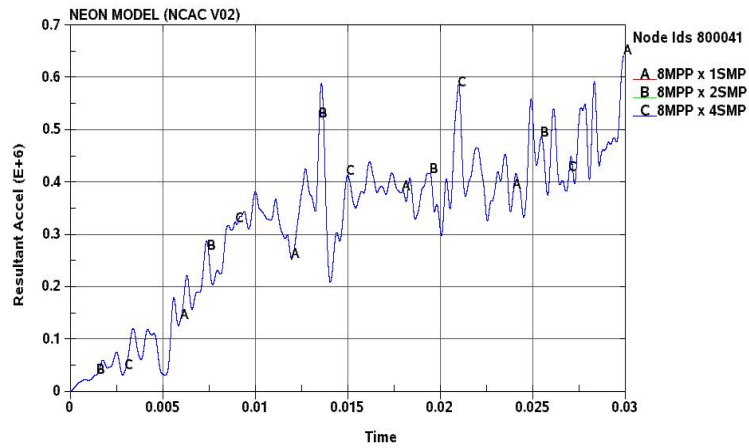

- Consistent results is be obtained with fix decomposition and changing number of SMP threads



Hybrid mpi/smp

ODB Proprietary Crash Model mpp971.R4.2.hybrid

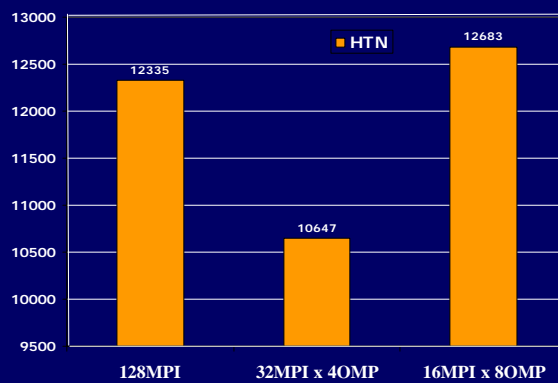

Hybrid mpi/smp

- mpp971.R4.2.hybrid.beta (consistency)

Neon model 30ms	16MPI x ncpu=-1 Total 16 cores	16 MPI x ncpu=-2 Total 32 cores	16 MPI x ncpu=-4 Total 64 cores	16 MPI x ncpu=-8 Total 128 cores
Elapsed Time	1480s/1.00	789s/1.88	510s/2.9	389s/3.8
Consistent result	Yes	Yes	Yes	Yes

3cars model 150ms	16MPI x ncpu=-1 Total 16 cores	16 MPI x ncpu=-2 Total 32 cores	16 MPI x ncpu=-4 Total 64 cores	16 MPI x ncpu=-8 Total 128 cores
Elapsed Time	7831s/1.00	4810s/1.63	3531s/2.22	3397s/2.31
Consistent result	Yes	Yes	Yes	Yes

3cars model 150ms	64MPI x ncpu=-1 Total 64 cores	64 MPI x ncpu=-2 Total 128 cores	64 MPI x ncpu=-4 Total 256 cores	64 MPI x ncpu=-8 Total 512 cores
Elapsed Time	2302s/1.00	1464s/1.58	1073s/2.15	1039s/2.22
Consistent result	Yes	Yes	Yes	Yes



Hybrid mpi/smp

- mpp971.R4.2.hybrid.beta (consistency)

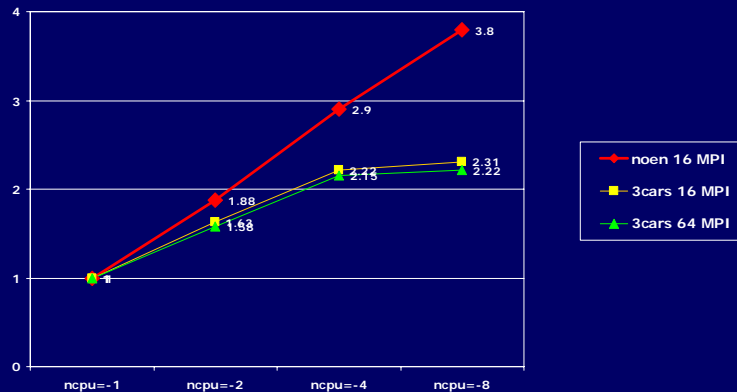

Performance comparison on Windows server 2008

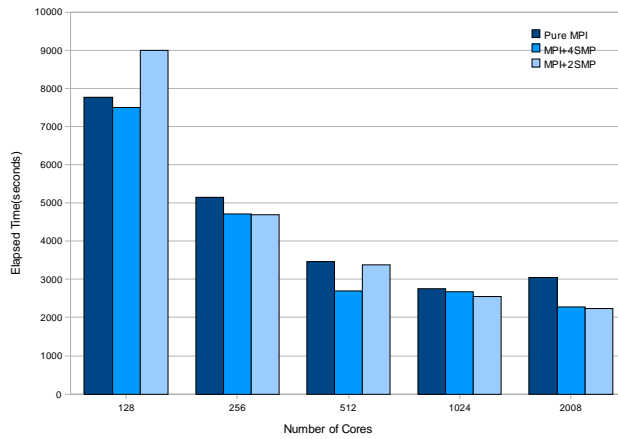

- SMP parallel in element processing and rigidbody calculations
- More performance is expected after SMP in contact algorithm



Message Across Network

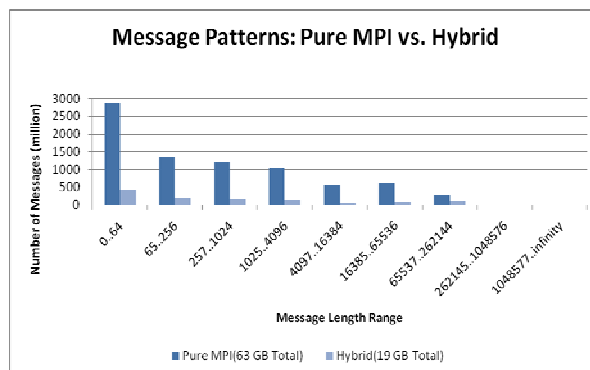

- Hybrid greatly reduce the amount of data through network and provide better scaling to large number of processors



Recent Developments in LS-DYNA® Part II

7th European LS-DYNA Conference

J.O. Hallquist

May 15, 2009



1

Outline of talk

- Part I
 - Introduction
 - LSTC dummy/barrier developments
 - Hybrid LS-DYNA
- Part II
 - Implicit update
 - Version 971 release 4 and later
 - Version 980
 - Conclusions



2

Implicit update

MPP implicit

- MPP Implicit is working well.
 - Time for factorization and solves are scaling very well
 - There are scalar memory bottlenecks in MPP Implicit that are not in explicit. They show up on problems with millions of nodes and hundreds of cores. We are working to reduce them.
 - We are testing the **hybrid** parallel implementation. It should be ready for adventurous users in June.

Silverado

LS-DYNA keyword deck by LS-Prepost

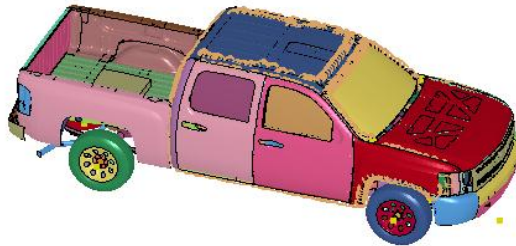

- Original from NCAC with .90M nodes
- Refined to have 1.8M and 3.6M nodes



5

MPP/Hybrid performance – 4 nodes

- Using 4 nodes and 1, 2, 4, and 8 cores/threads per node, all available memory the wall clock time results

MPI			MPI+OPENMP		
No. of cores/node	Factor WCT	Solve WCT	No. of cores/node	Factor WCT	Solve WCT
1	123.0	3.5	1	127.1	3.5
2	68.4	2.1	2	79.9	2.1
4	44.6	1.7	4	51.4	1.7
8	27.3	1.3	8	37.6	1.3



6

MPP performance – 8 nodes

- Using 8 nodes and 1, 2, 4, and 8 cores per node, all available memory the wall clock time results for Silverado .85M node / 5.3M row model

No. of cores/node	Factor WCT	Solve WCT
1	68.5	1.9
2	44.8	1.4
4	26.5	0.9
8	19.8	0.9

Gravity loading

- Robust contact treatment
- Vehicle does not need to be supported to eliminate rigid body modes
- Elimination of loose parts not required
 - Reduces model preparation time dramatically over traditional implicit method.
- User-independent results
- The reduction in CPU cost over dynamic relaxation is significant

NCAC Silverado pickup

- 929071 elements and 942655 nodes
- 1 contact_spotweld
- 1 type13 contact for entire vehicle
- 1 rigidwall for tire to ground
- Computational times on SGIXE1
 - MPP 16 cpus 1 hour 19 minutes, 24 iterations
 - Memory per proc 476 Mwords
 - MPP 32 cpus 52 minutes, 26 iterations
 - Memory per proc 269 Mwords

Future developments

- Enable the use of this method in a seamless 4 phase run.
 - Pressurizing tires – Implicit – phase1
 - Apply gravity – Implicit – phase2
 - Crash - Explicit – phase3
 - Springback – Implicit – phase4

Version 971_R4

User-Defined Elements

- Implemented for solids and shells.
- Permits new element types to be defined entirely by keyword input.
- Interpolation elements allow output to LS-Prepost.
 - Contact
 - Boundary conditions
- Intended for researchers and students.
 - Research: isogeometric elements.
 - Students: implement elements as homework.
- Analysis types:
 - Explicit, Implicit quasi-static and dynamic

Isogeometric Analysis

Example of User-Defined Elements

- Isogeometric analysis uses NURBS as basis functions.
- NURBS are the basis functions used in CAD programs.
- Therefore: facilitates direct CAD to analysis interface.
- NURBS are nicely behaved.
 - Improved numerical conditioning.
 - Larger time step size for higher order elements than for Lagrangian polynomials.



13

Shell Formulations

- 3 types currently available.
 - IFORM=0: Degenerated solid element with rotational DOF.
 - IFORM=2: Thin shell without rotational DOF.
 - IFORM=3: Reissner-Mindlin with rotational DOF.

$$v_i(\xi) = \sum_{A=1}^n N_A(\xi) \left(v_{Ai} + \frac{h\xi_3}{2} e_{ijk} \omega_{Aj} n_{Ak} \right)$$

$$v_i(\xi) = \sum_{A=1}^n N_A(\xi) v_{Ai} + \frac{h\xi_3}{2} \sum_{B,k} \frac{\partial n_i(\xi)}{\partial x_{Bk}} v_{Bk}$$

$$v_i(\xi) = \sum_{A=1}^n N_A(\xi) \left(v_{Ai} + \frac{h\xi_3}{2} e_{ijk} \omega_{Aj} n_k(\xi) \right)$$



14

Square tube buckling

Quadratic ($P=2$) and Quartic ($P=4$) NURBS Elements

- Isogeometric NURBS basis functions
 - Quadratic (s^2) and quartic (s^4) functions
 - 3 integration points through the thickness
- 858 control points (nodes)
- 640 quadratic elements
- Perturbation of control points (nodes) with amplitude of 0.05 at $y=67.5$
- *MAT_KINEMATIC_PLASTIC with isotropic hardening
- We are starting the work to make NURBS Elements directly available



15

Square tube buckling

Quadratic ($P=2$) NURBS Shell Elements

square cross section for single surface
Time = 0
Contours of Effective Plastic strain
max (gt) value
min=0, at elem# 1001
max=0, at elem# 1001

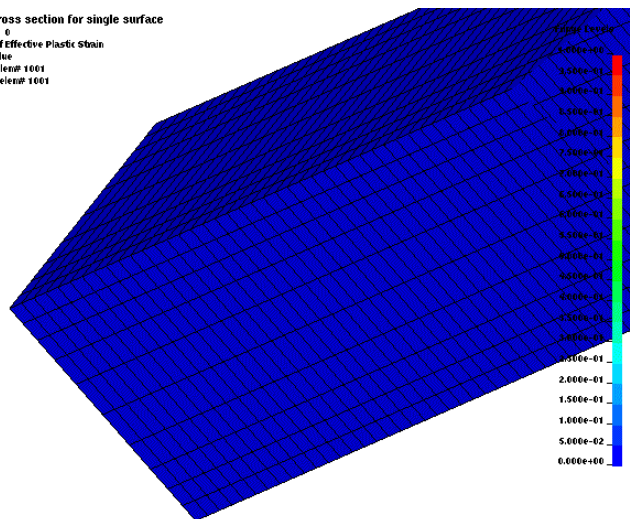

16

Square tube buckling

Quartic ($P=4$) NURBS Shell Elements

square cross section for single surface
Time = 0
Contours of Effective Plastic Strain
max=0, at elem# 1001
min=0, at elem# 1001

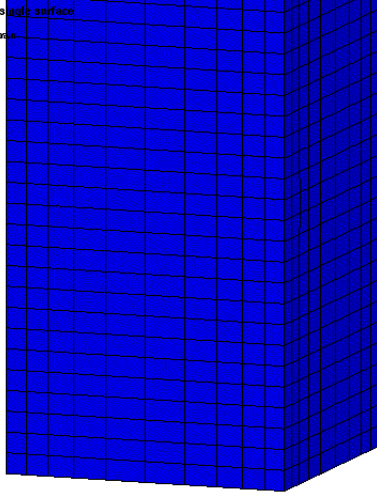

Fringe Levels
1.000e+00
9.500e-01
9.000e-01
8.500e-01
8.000e-01
7.500e-01
7.000e-01
6.500e-01
6.000e-01
5.500e-01
5.000e-01
4.500e-01
4.000e-01
3.500e-01
3.000e-01
2.500e-01
2.000e-01
1.500e-01
1.000e-01
5.000e-02
0.000e+00



17

Particle airbag method

- Gas mixtures
- Moving point sources and multiple inflators
- Airbag deployment in moving vehicle
- Robust contact algorithms for tightly folded bags
- Fabric porosity
- Treat external and internal vents
- Blockage considered for porosity and venting
- Switch from particle method to control volume to save CPU time
- Serial, SMP, and MPP support



18

Particle method-new features

Dynamic radius - IRDP

- Particle size is adjusted automatically based on potential collision rate to keep reasonable mean free path

$$l = \frac{1}{\sqrt{2} \cdot \pi d^2 \cdot n}$$

- Particle moves easier in tight space to give reasonable flow rate (gas guide tube)
- Particle collision rate higher in open spaces

*AIRBAG_PARTICLE

SID1 STYPE1 SID2 STYPE2 BLOCK HCONV FRIC IRDP

IRDP: Eq.0 off (Default)

Eq. 1 on



19

Particle method-new features

Dynamic radius – IRDP

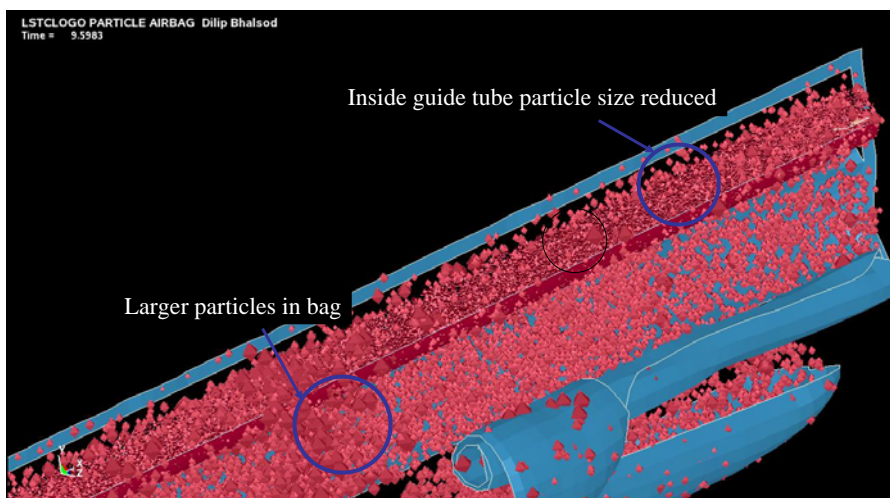

20

Particle method-new features

Inflator gas flow and momentum transfer

$$E_{inlet} = E_{flow} + E_{Maxwell-Boltzmann}$$

- More realistic inflow condition using flow speed
- Particles carry thermal velocity to avoid artificial jet in the inlet
- The cone angle (CAi) is hence obsolete from release 4
- New option is available to measure and apply reaction forces to inflator from inlet gas impulse (IMOM)

*AIRBAG_PARTICLE

.....

NORIF cards

NIDi ANi VDi CAi INFOi IMOM

IMOM: Eq.0 off (Default)

Eq. 1 on



21

Particle method-new features

Inflator gas flow and momentum transfer

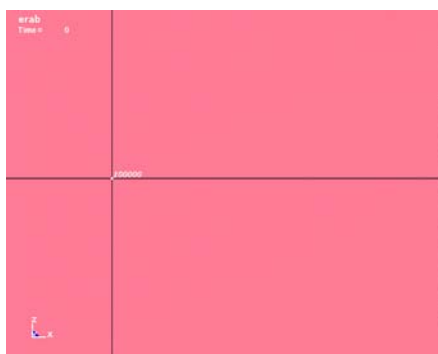

Release 3

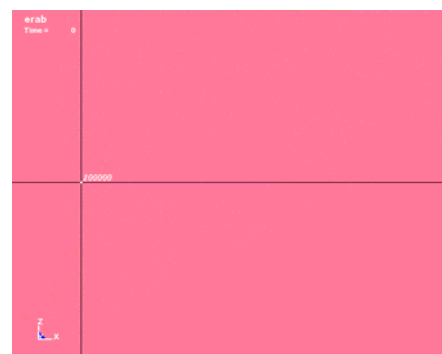

Release 4



22

Contact_beam_to_surface

The need for simple and efficient beam to surface contact:

- Analysis of cables contained within a conduit or cables adjacent to a structural surface subjected to static and dynamic loading
- Human body modeling of muscles and tendons interacting with skeleton
- Interaction of woven fabrics on discretized surfaces
 - Beam to beam contact treats the fiber contact in the woven fabric

Contact_beam_to_surface

New keyword:

- ***CONTACT_AUTOMATIC_BEAMS_TO_SURFACE**
- Compatible with the beam-to-beam contact type, AUTOMATIC_GENERAL, which allows both contact types to function together in analyzing woven fabric interacting with surfaces
- Speed advantage over current methods
 - Avoids beam to beam contact checking of the GENERAL option
- Accuracy over node to surface contact types
 - Provides continuous force distribution due to beam contact

Neck-cable interaction

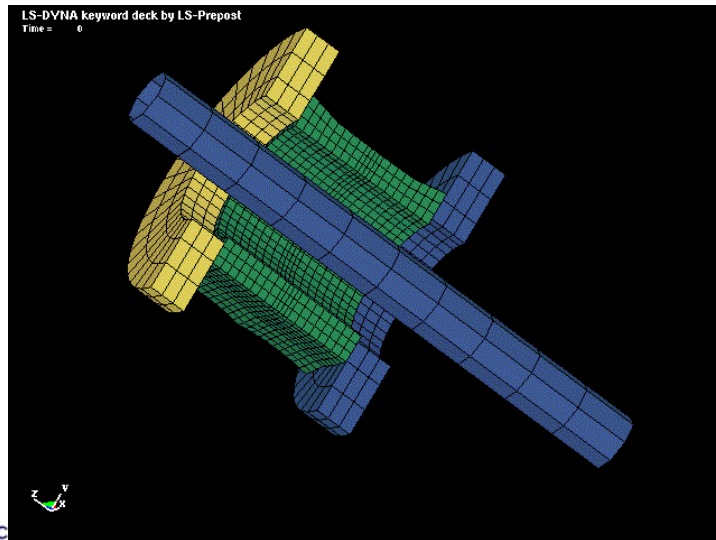

25

*Define_function

- Arithmetic expression involving a combination of independent variables and other functions, i.e.,
 - $f(a,b,c)=a^2+b*c+\text{sqrt}(a*c)$where a, b, and c are the independent variables.
- The function name, f(a,b,c), must be unique since other functions can then use and reference this function.
 - $g(a,b,c,d)=f(a,b,c)**2+d$.

26

*Define_function

- Implemented for a subset of keywords
 - *ELEMENT_SEATBELT_SLIPRING
 - *LOAD_BEAM
 - *LOAD_MOTION_NODE
 - *LOAD_MOVING_PRESSURE
 - *LOAD_NODE
 - *LOAD_SEGMENT
 - *LOAD_SEGMENT_NONUNIFORM
 - *LOAD_SETMENT_SET_NONUNIFORM
 - *BOUNDARY_PRESCRIBED_MOTION
- No change in input is required. If a curve ID is not found, then the function ID's are checked

Slow speed impact

- Slow speed impact can be noisy due to single precision
- Double precision eliminates problem but runs significantly slower
 - Arithmetic operations are more costly
 - Message length of communicated data under MPI doubles
- By keeping all arrays related to the global coordinates in double precision the problem is now solved
 - Only small slowdown relative to R3 due to additional double precision arithmetic and message lengths
- We are now confident that single precision can continue to be used for crash analysis for the next decade

*Element_seatbelt_slipping

Frictional sliding of belt over slipping can now be specified as a function of two angles.

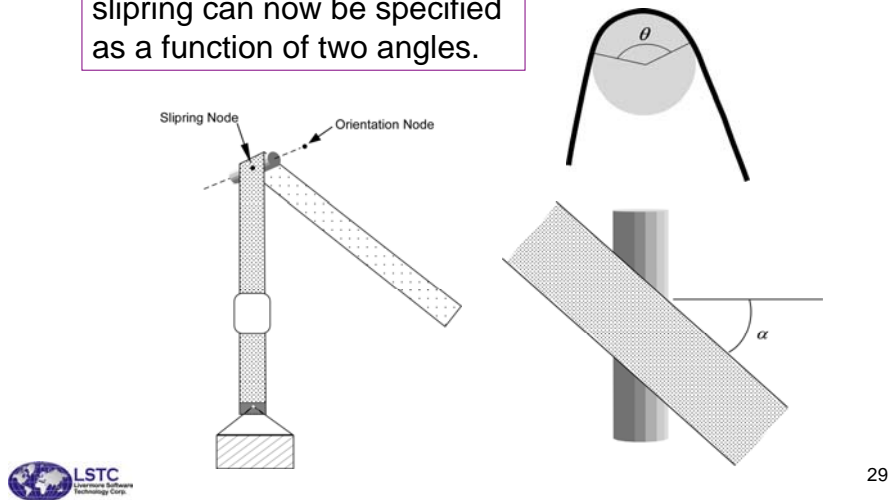

New network license server

- Until now, LS-DYNA used a single server to handle network licensing. When the server dies, initiating new runs is prohibited.
- We have now extended our license server into a **Redundant Network License Server**
 - License servers work in tandem. No problem if one dies.
 - Full recovery after restart even if all servers fail
 - Enhanced logging and diagnostics + remote diagnostics
 - Uninterrupted by changes in redundant servers
 - License file format adds new keys for servers & ports
 - Preferred license server order can be changed by customer
 - Port numbers can be changed by customer
 - Installed at GM and Ford

Encrypted input

- Encryption is now available to protect proprietary material input data
 - Uses **openPGP** standard format, so data can be encrypted with widely available tools such as **gpg**
 - Public key encryption with 1024 bit DSA key and 128 bit AES
 - Any subset of input lines may be encrypted except ***INCLUDE** statements, and initial ***KEYWORD**
 - Multiple encrypted sections allowed, without limitation
 - Material properties defined in encrypted blocks will not be echoed to d3hsp or other output files.

*Element_mass_part_{set}

- Defines additional non-structural mass to be distributed by an area/**volume** weighted distribution to all nodes of a given part or part set ID
 - The total added mass can be specified
 - The final mass of the part or part set can be specified and the added mass computed automatically
- Initially for shell elements **but now extended to part ID's defined by solid elements.**
- Provides an alternative method to giving the non-structural mass per unit area in the section definition

*Define_curve_duplicate

- Define a curve by optionally scaling and offsetting the abscissa and ordinates of another curve defined by the *Define_curve keyword.
- Substantially simplifies input when many curves are required

*Termination_deleted_solids

- Similar to *Termination_deleted_shells
- Terminates the calculation whenever the number of deleted solids for a specified part ID exceeds a defined value
 - No effect for solid element part ID's left undefined

*Boundary_spc_...

- New option added to the *Boundary_spc keyword:
- Birth_death
 - SPC becomes active at the birth time
 - SPC becomes inactive at the death time

User material and user eos

- In version R4 it is now possible to combine user material models with user equations-of-state (eos).
 - Implemented for 3D solid elements
 - Implemented for 2D solid elements in next release
 - The user material ID and user eos ID are referenced on the part card and there are no other special requirements.

Improvements to solids type 3/4

- Solid elements with rotational degrees-of-freedom include the type 3 brick and type 4 tetrahedron:
- These elements are now extended to treat large strains and large rotations.

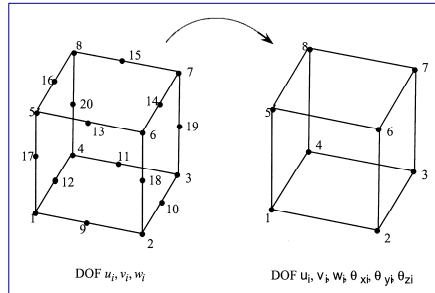

Enhanced-strain solids

- Solid element type 2 shear locks when the aspect ratio are poor
 - Base on selective reduced integration
 - Avoids volumetric locking
- Two new fully integrated solid elements are implemented that overcomes shear locking
 - Type -2 which is approximately 2.9 times more costly
 - Type -1 which is approximately 1.5 times more costly
 - Implicitly
 - Works for linear and nonlinear large deformation problems

Fully automatic line die simulation

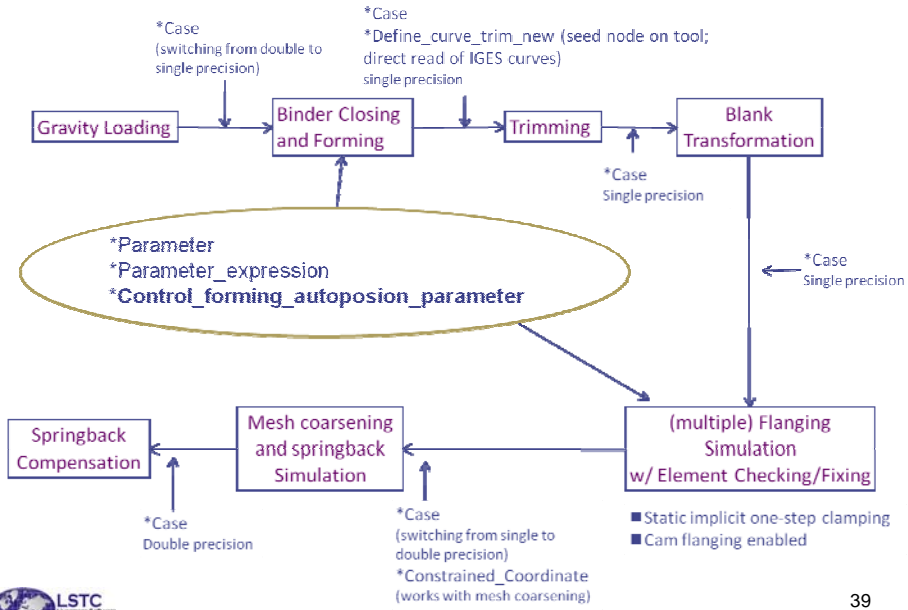

Note: All tools must be defined in home position

Version 980



Version 980

- Version 980 has been under development for 6 years
- Adds to the multi-physics capabilities
 - Electromagnetics
 - No cost licensing for users willing to test capabilities
 - Incompressible fluid solver
 - Compressible fluid solver based on CESE
- Full structural and thermal coupling between solvers



41

LS980-Electromagnetism

- Electromagnetism module for 3D eddy-current problems, coupled with mechanical and thermal solvers (typical applications: magnetic metal forming and welding).
- Boundary element method in the air coupled to finite elements in the conductor is used to avoid meshing the air.
- The EM fields, as well as EM force and Joule Heating can be visualized with LSPREPOST.



42

Electromagnetism module

- MPP version now available.
- Different solvers with different pre-conditioners
- Electromagnetism contact capability under development
- Future:
 - Introduction of other solvers than eddy-current (magneto statics,...)
 - Introduction of non magnetic material.



Electromagnetic forming

Courtesy of Ibai Ulacia, University of Mondragon, Spain

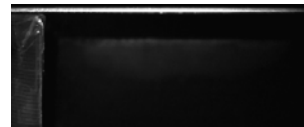
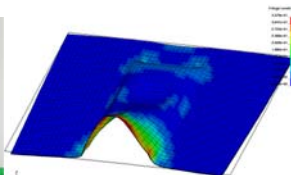

PHOTRON High speed camera
Sampling rate: 37500 fps

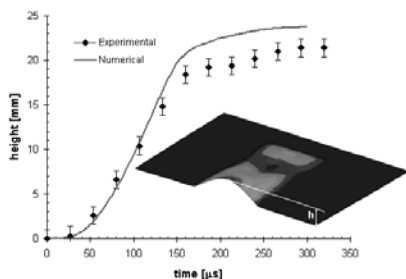

Exp. Vs simulation

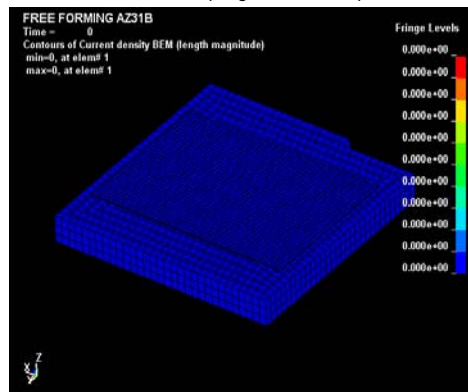

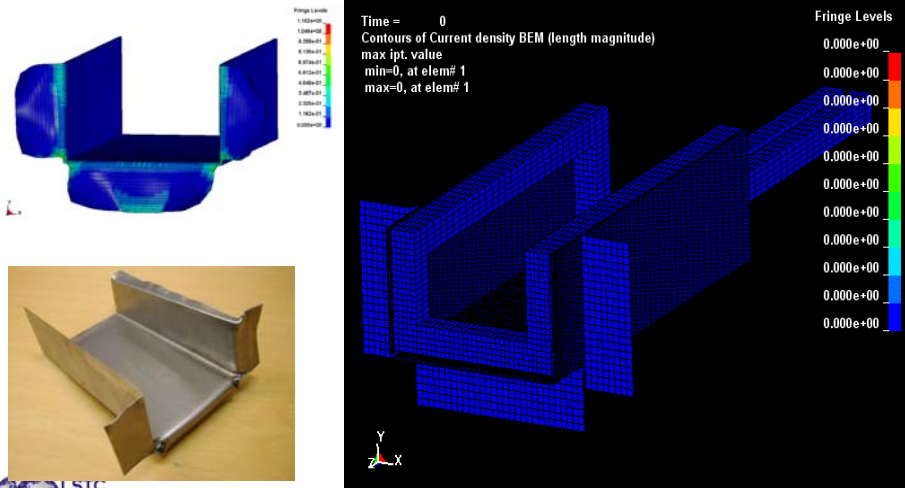

Incompressible flow solver

- Finite Element formulation for the [Navier Stokes equations](#)
- [Implicit](#) CFD and FSI analysis [strongly coupled](#) to implicit and explicit solid mechanics.
- Support for [mesh movement and large deformations](#) keeping the mesh body fitted at all times.
- [High level mesh manipulation](#). Automatic volume meshing and run time re-meshing.
- [Error control](#) and adaptivity
- [Turbulence](#)
- [Free surface](#) and [multi-phase](#) approximations

Incompressible FSI application: artery flow

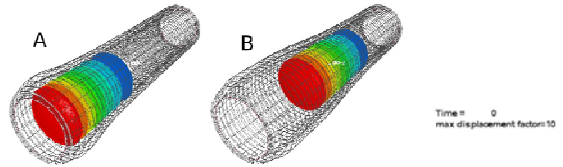
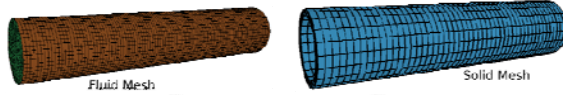

Fluid Pressure and Structure Deformation

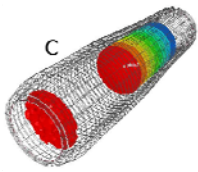

- * Strong Fluid-Structure interaction coupling is mandatory for bio-medical applications
- * Miss-match fluid and structure mesh allows proper resolution for each domain

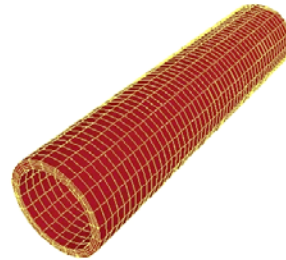

Flow Around a Parachute Structure

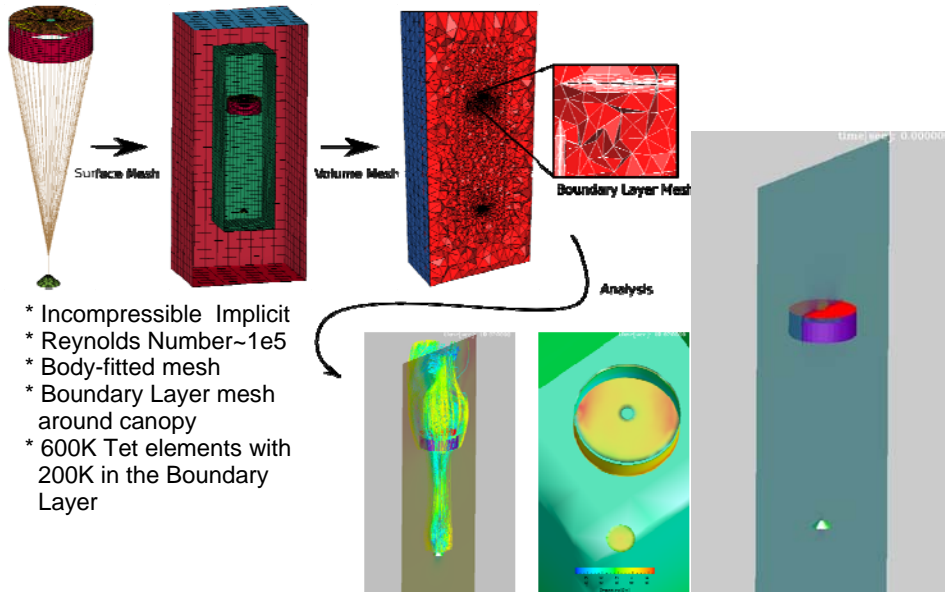

- * Incompressible Implicit
- * Reynolds Number~ $1e5$
- * Body-fitted mesh
- * Boundary Layer mesh around canopy
- * 600K Tet elements with 200K in the Boundary Layer

Streamlines and Pressure (from below) after 20 Second s of simulation



Flow interaction between 4 parachute canopies

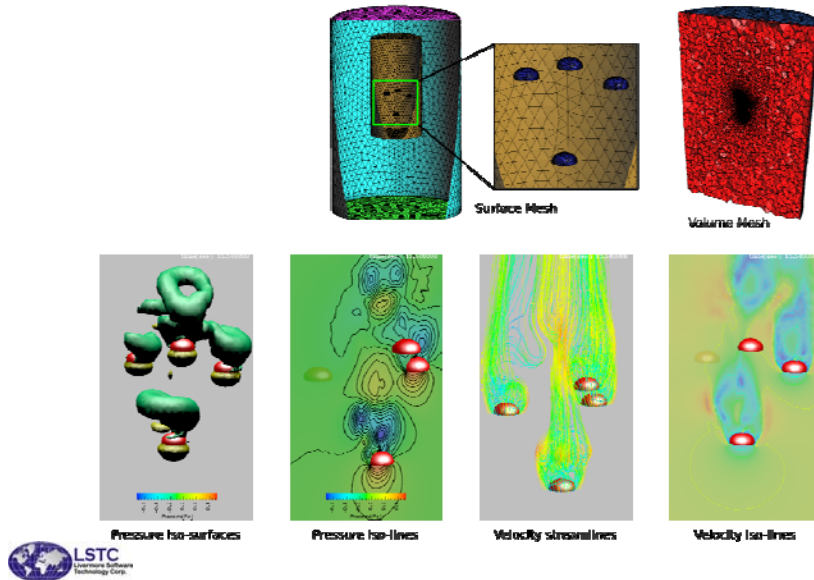

49

CESE Method

- Advantage of CESE method for compressible flow:
 - Flux conservations in *space and time* (locally & globally)
 - 2nd order accurate
 - Novel & simple shock-capturing strategy
 - Both strong shocks and small disturbances can be handled very well simultaneously

50

Current status

- **Codes:** Serial & MPP modes
(fluid solver input deck setup is very simple)
- **Flows:** Compressible inviscid & viscous flows
- **Meshes:** Hexahedra, wedges, tetrahedra
- **BCs:**
 - Regular boundary conditions (solid, open, inflow, outflow, symmetric)
 - Moving or rotating solid boundaries for viscous flows (in tangential directions)

FSI with CESE

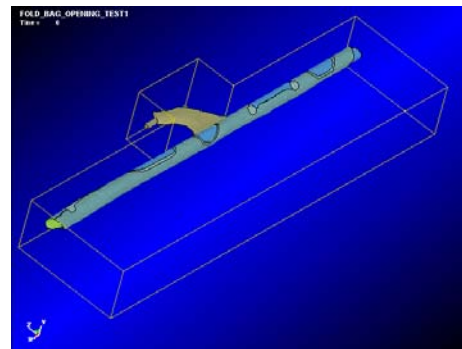
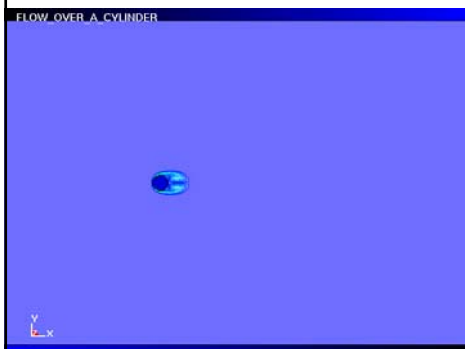

Conclusions: summary

- LSTC is committed to be the leader in large scale numerical simulations
 - LSTC is committed to providing dummy, barrier, and head form models with LS-DYNA to reduce customer costs.
 - LS-Prepost and LS-Opt are continuously improving and gaining more usage in the LS-DYNA community
 - LSTC is actively working on seamless multistage simulations in automotive crashworthiness, manufacturing, and aerospace
 - The implicit solver is quickly gaining market acceptance for nonlinear implicit calculations and simulations
 - Robustness, accuracy, and scalability has rapidly improved



53

Conclusions: future

- LSTC is not content with what has been achieved
 - New features and algorithms will be continuously implemented to handle new challenges and applications
 - Electromagnetics,
 - Acoustics,
 - Compressible and incompressible fluids
 - Multiscale capabilities are now under development with initial release later this year
 - Hybrid MPI/OPENMP developments are showing significant advantages at high number of processors for both explicit and implicit solutions



54