

Visualisierung von Ergebnissen aus Optimierungs- und DOE-Studien

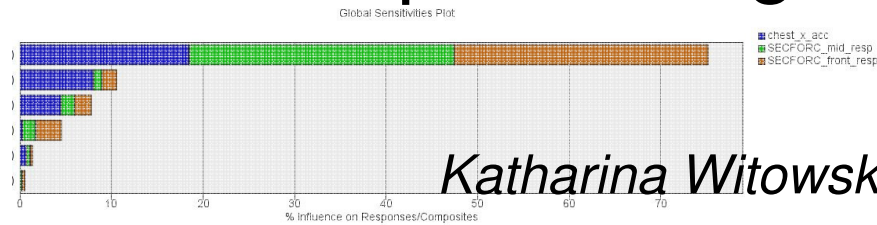

Katharina Witowski, Heiner Müllerschön
DYNAmore GmbH, Stuttgart, Germany

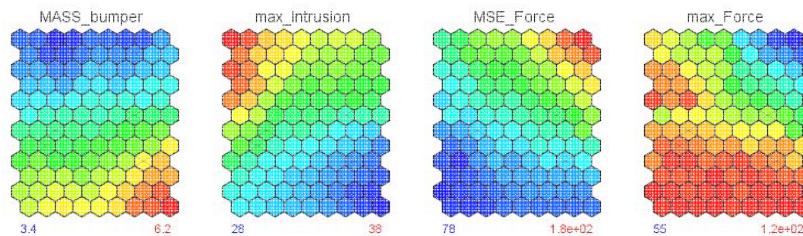
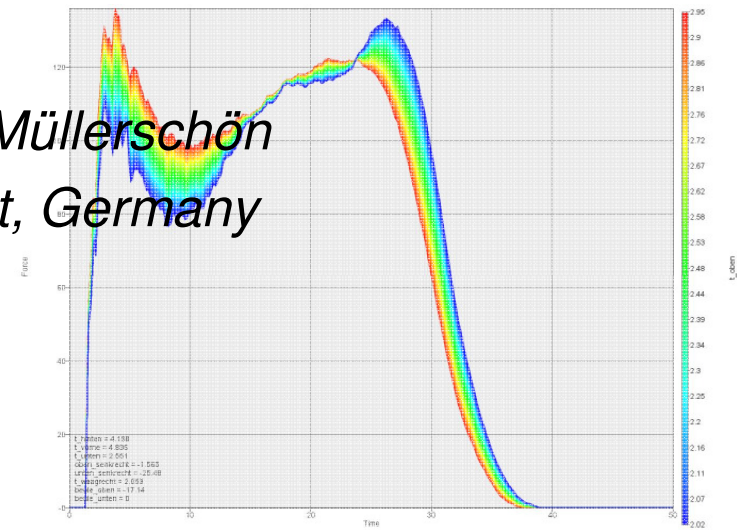
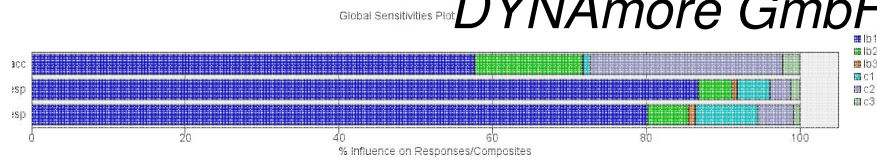

Overview

- Example: Optimization of a crash management system
 - Problem description
 - Visualization of Pareto optimal solutions
 - SOM
 - Parallel coordinate plot
 - Visualization of history curves and predicted histories
- Example: DOE study of a front crash
 - Problem description
 - Visualization of sensitivities
 - Correlation matrix
 - Linear ANOVA
 - Global sensitivities (Sobol)
 - Interpolator plot
- Summary

Optimization of a Crash Management System

- Load case 1: AZT crash repair test

mass barrier: 1000kg
mass vehicle: 1514.53kg

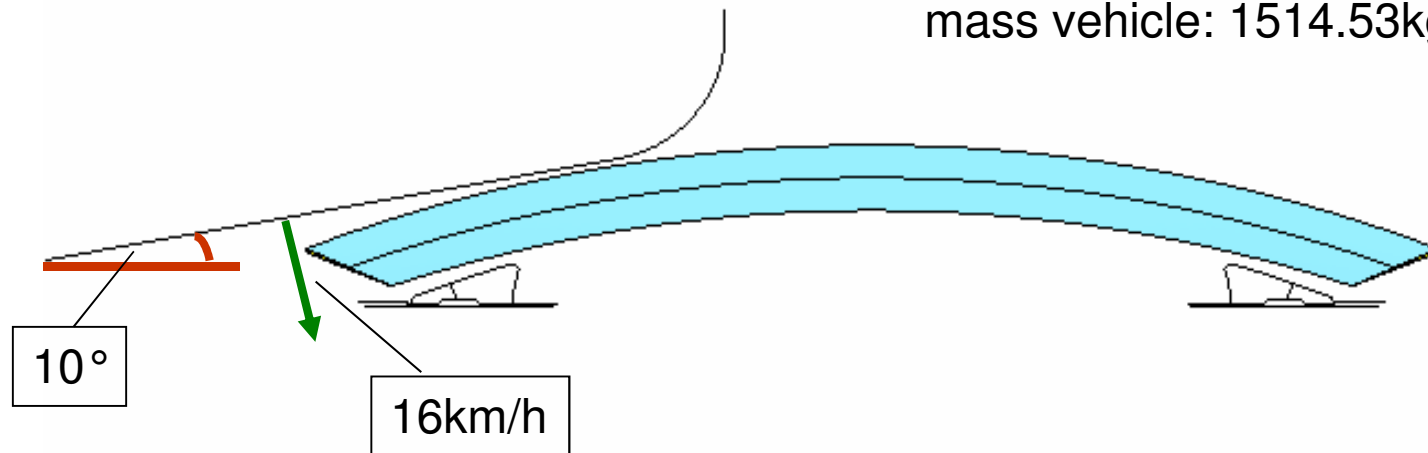

- Load case 2: RCAR test

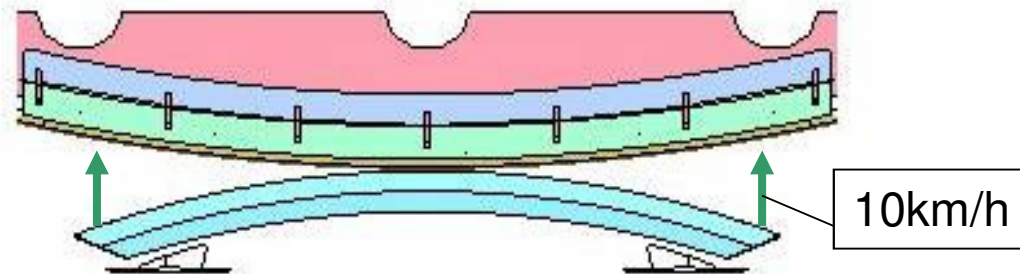

Problem Description

- Objective: optimize the energy absorption by plastic deformation of the bumper
- Given maximal force level for load case AZT (barrier contact force)
- Bumper has extruded section → constant cross section

Problem Description

- 9 design variables
 - 4 Morphing parameters (ANSA as preprocessor in LS-OPT)
 - 5 sheet thicknesses

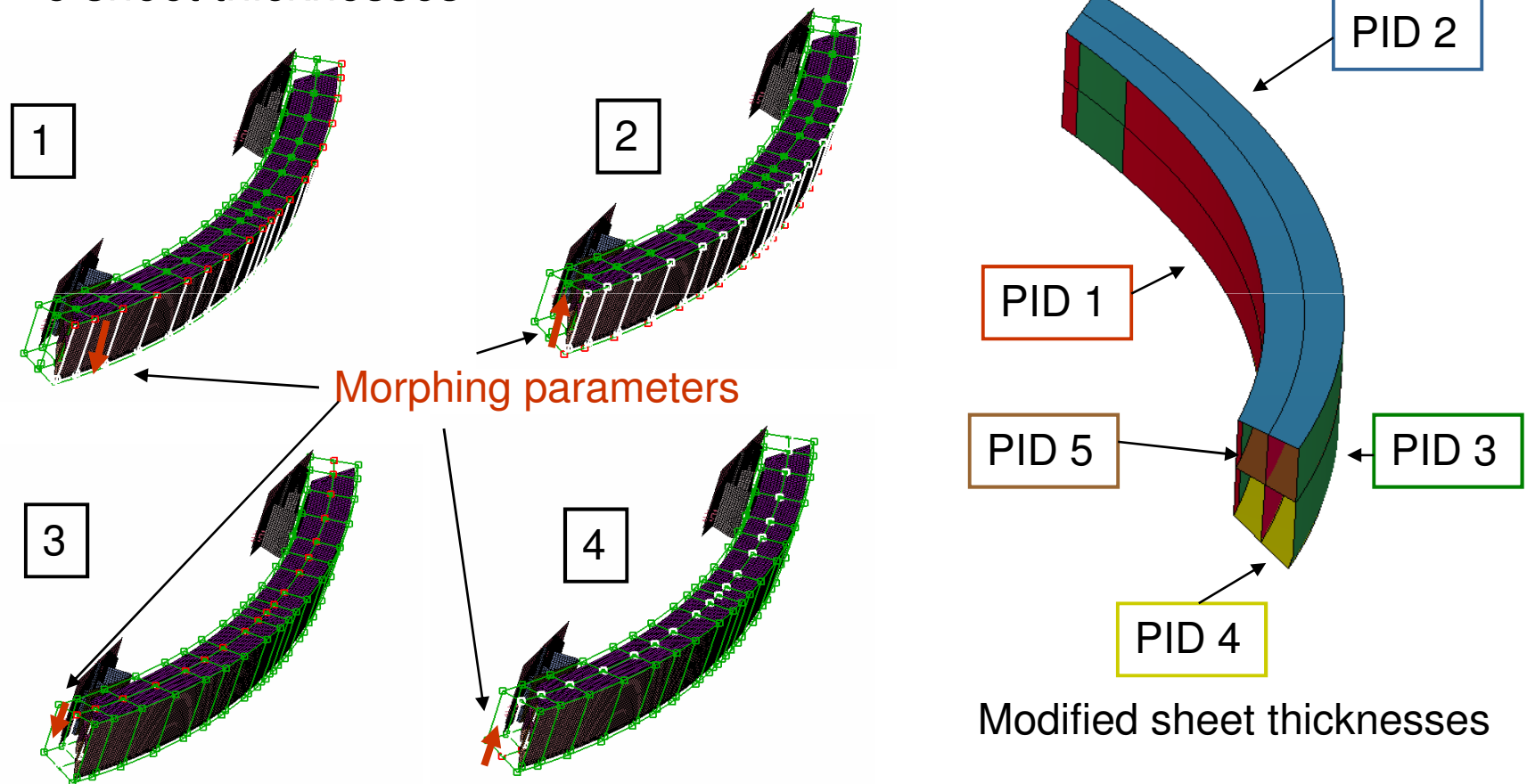

Resulting Bumper Shapes

- Some resulting bumper shapes of ANSA morphing

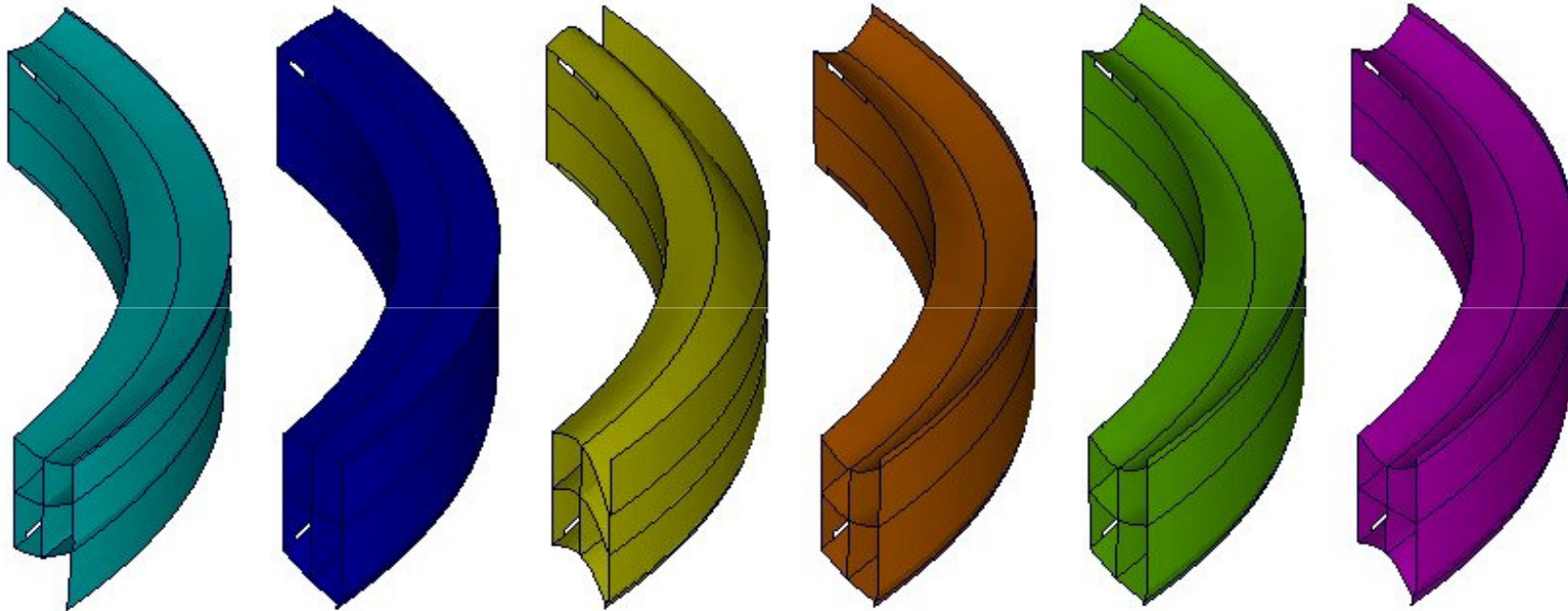

Problem Description

➤ 3 Objectives

- MSE_Force (load case AZT)
 - sum of squares error between calculated contact force curve and given constant contact force c

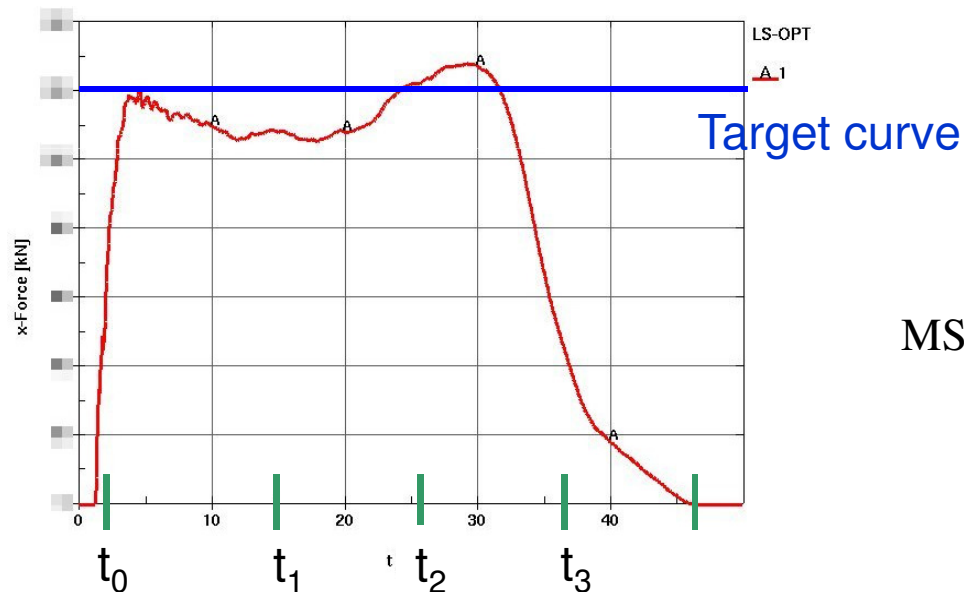

$$\text{MSE_Force} = \sqrt{\sum_{i=0}^3 (F(t_i) - c)^2}$$

Problem Description

➤ 3 objectives

– Max_Intrusion (load case RCAR)

→ Intrusion = displacement of center of mass of vehicle

- displacement of inner edge of bumper

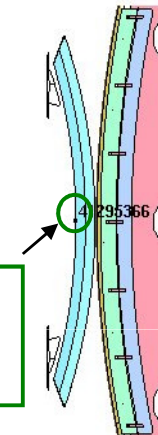
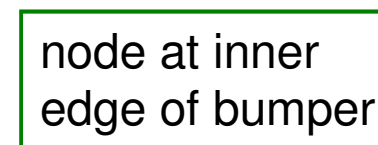
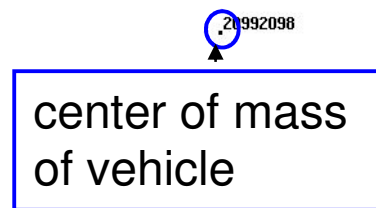

– Total mass of the bumper

➤ constraint: contact force $< C$

➤ Multi-Objective optimization → set of Pareto optimal solutions (metamodel-based)

Visualization

- Self organizing maps (SOM) → Conflicting objectives
 - Unsupervised neural network algorithm
 - Projects n-dimensional data onto two-dimensional array of nodes
 - Each node is associated with n-dimensional weight vector
 - Algorithm sorts and adapts weight vectors such that similar data is mapped to the closest node
 - Component map: visualizes one component of weight vector by coloring the grid according to the value of selected component

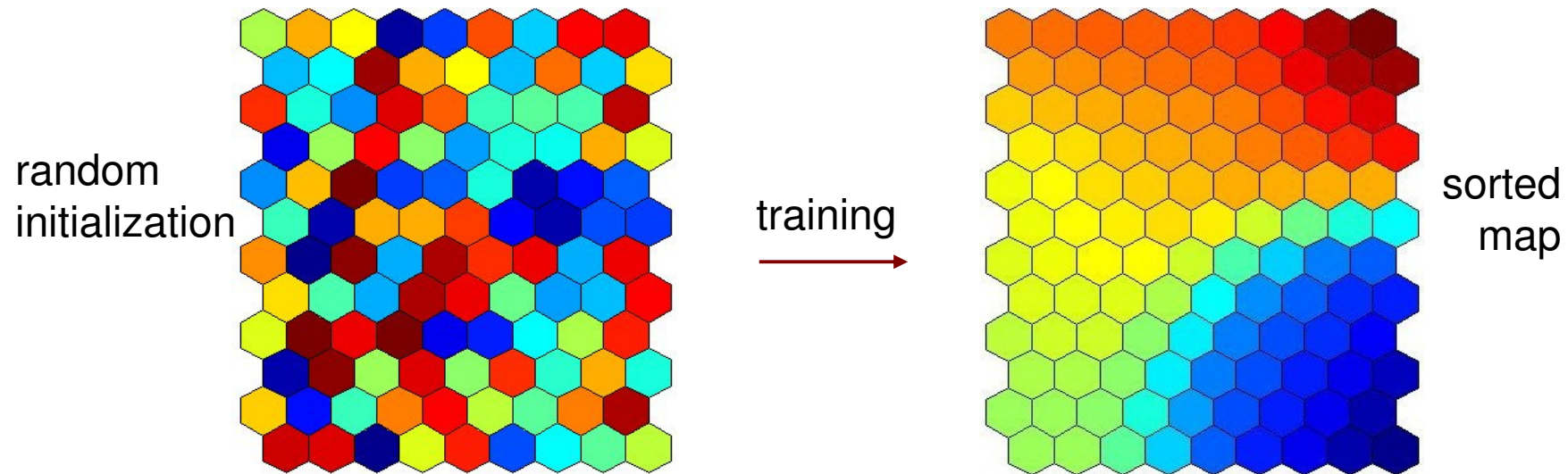

Visualization

- SOM (Self Organizing Maps) → (inverse) correlation of entities
- Component maps of objectives and constraint

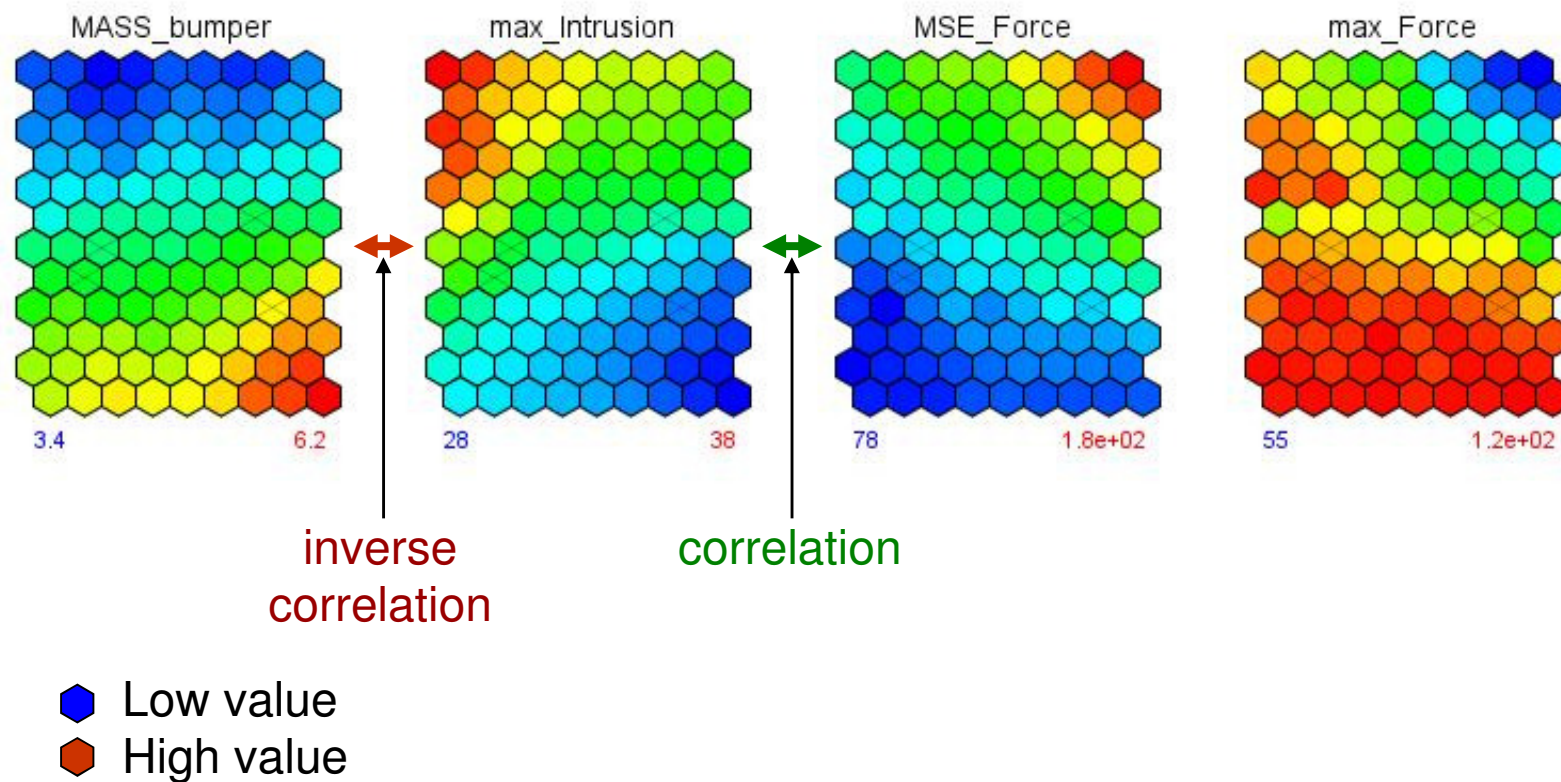

Visualization

- Parallel Coordinate Plot → Reduce number of suitable solutions by restricting ranges of objectives

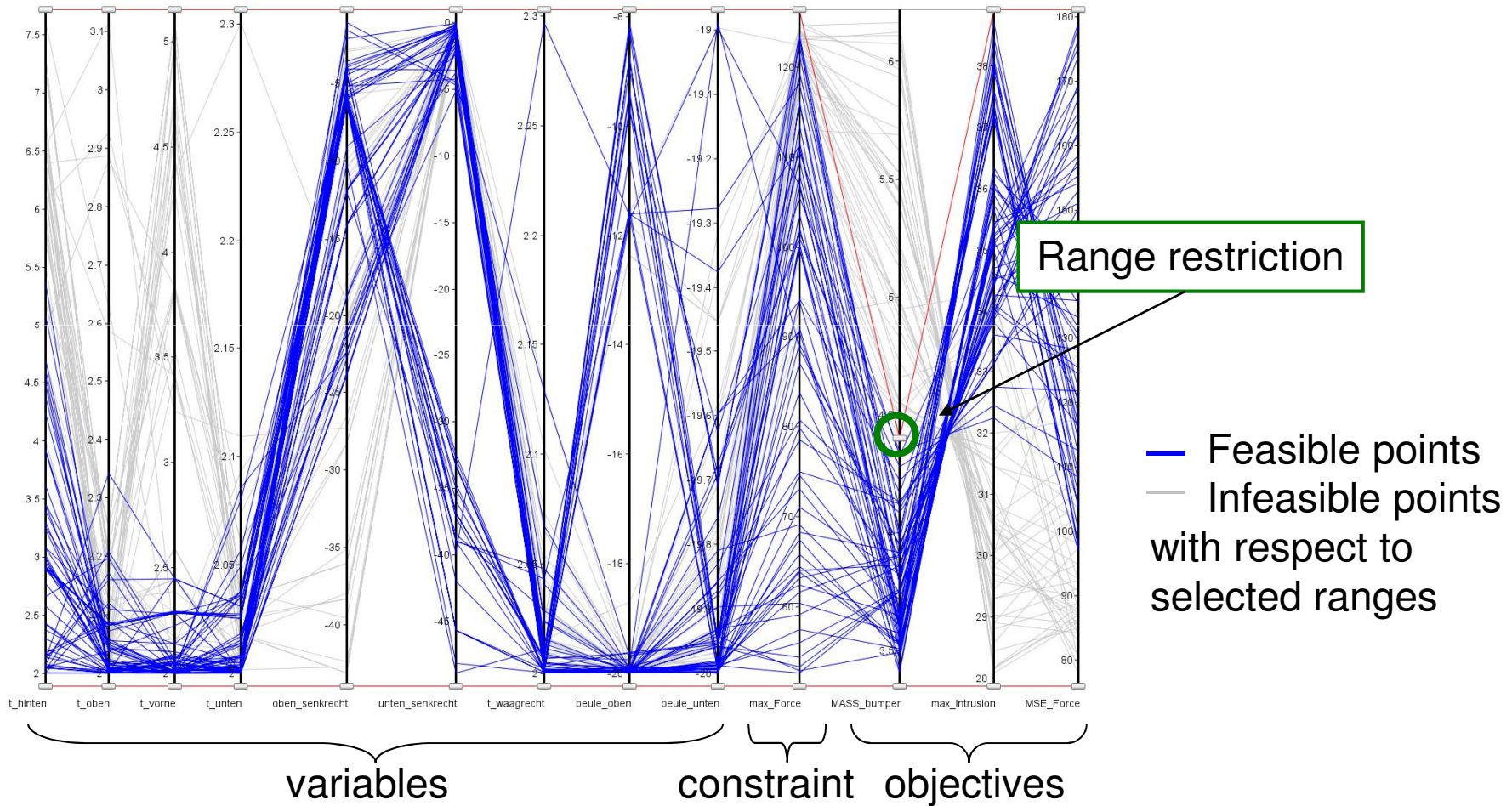

Visualization

➤ History curves: contact force curve

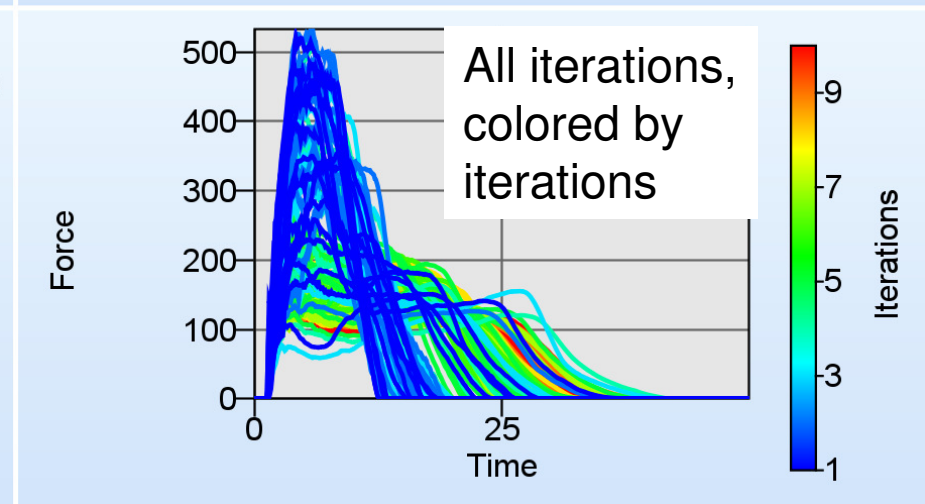
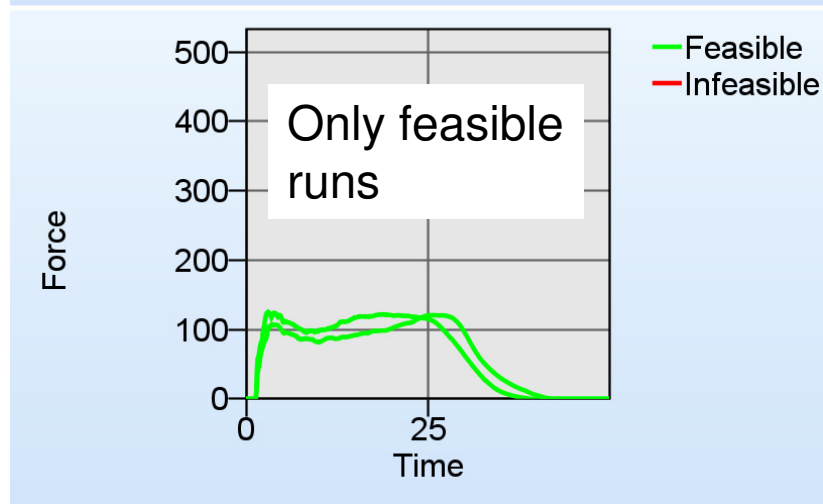
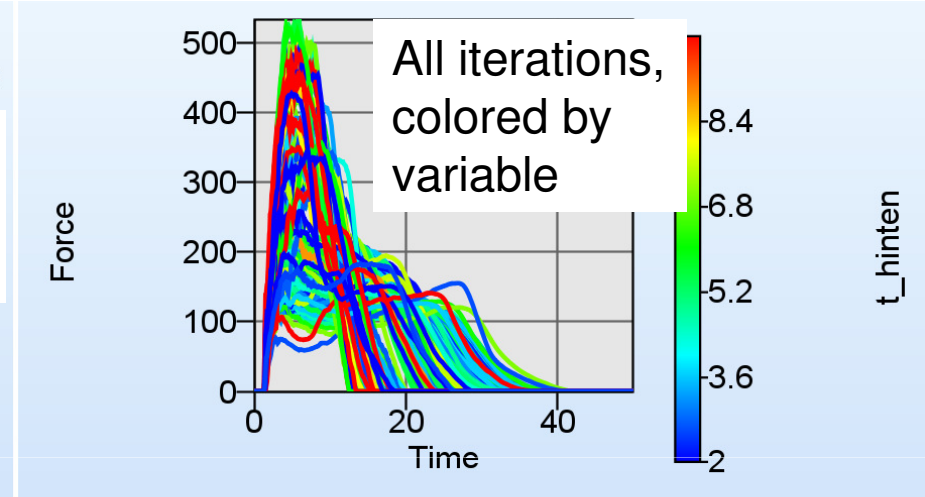
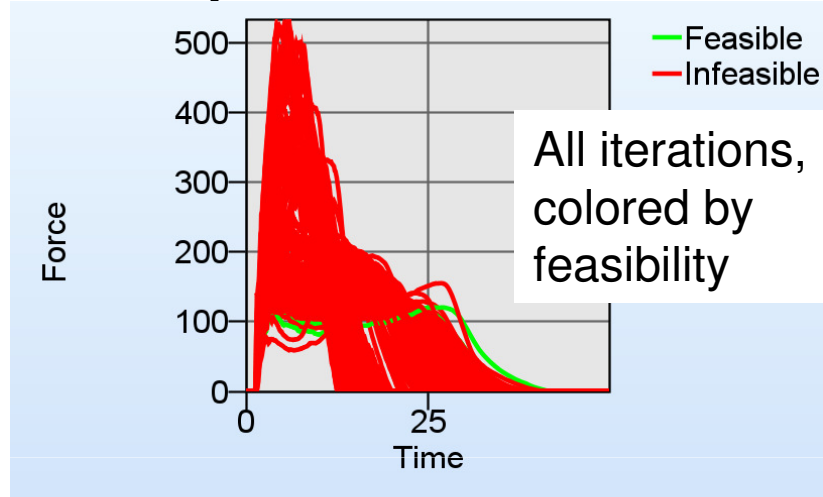

Visualization

- Predicted Histories – extension of metamodel concept to curve data

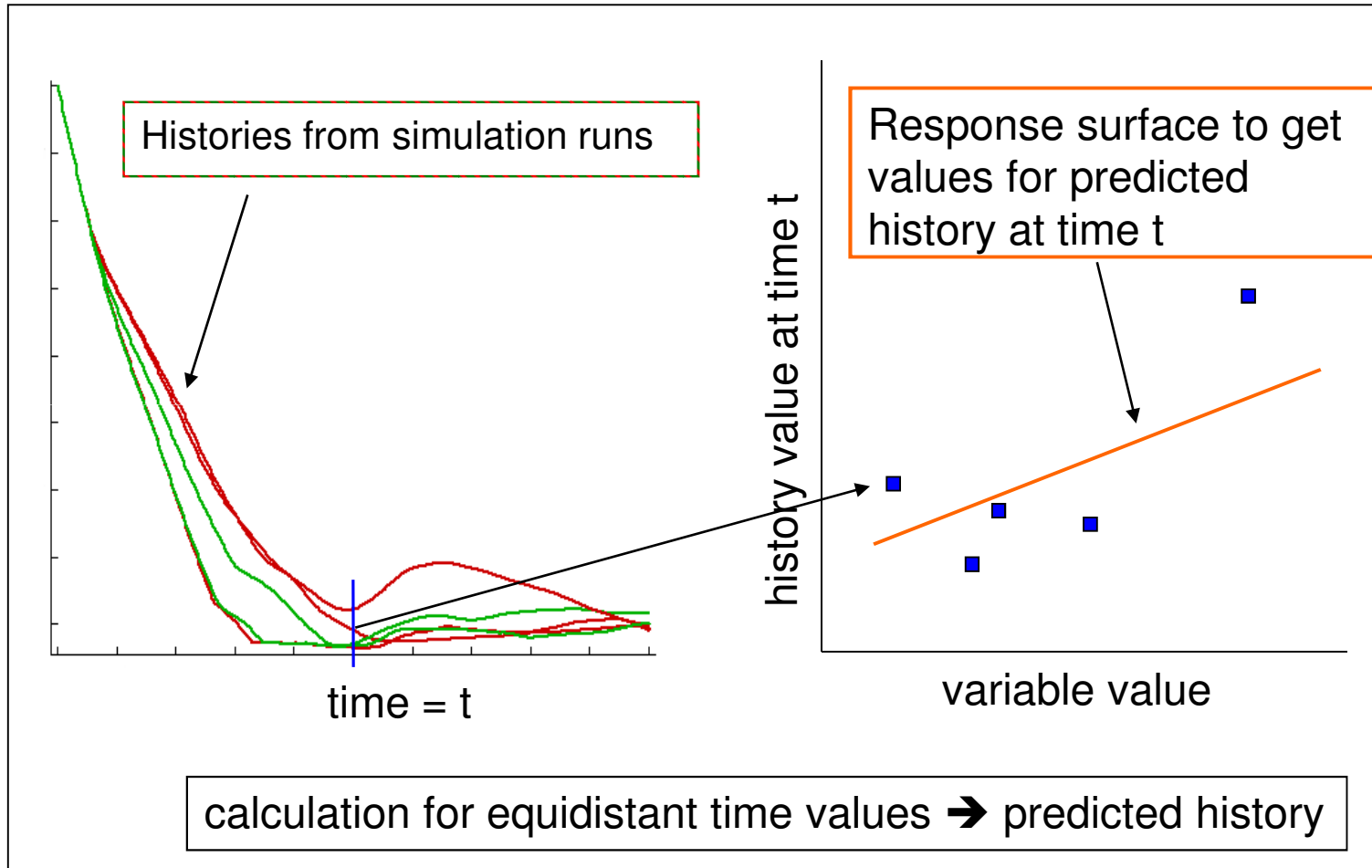

Visualization

- Predicted History colored by variable
 - curves for the whole range of the selected variable are displayed
 - visualizes the effect of a single parameter on the curve

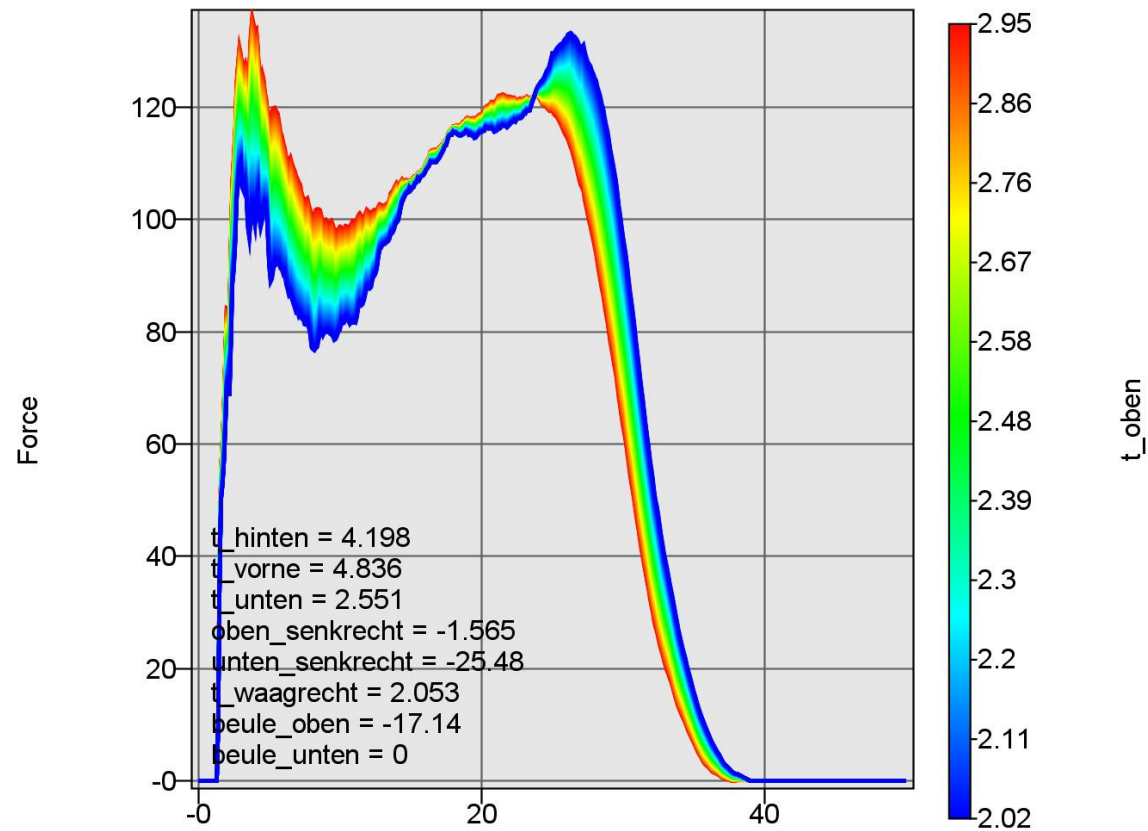

Visualization

- Predicted History Plot with variable values evaluated from a selected Pareto optimal point

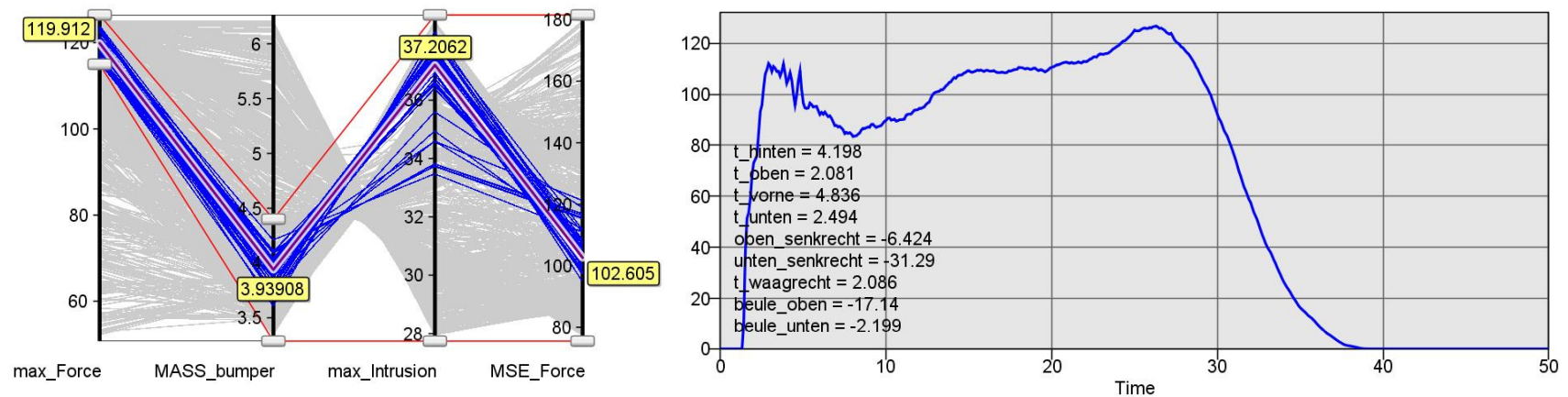

- Selection of suitable points out of the set of Pareto optimal solutions
 - Store variable values in a .csv file
 - user-defined sampling in LS-OPT
 - verification runs for the predicted results can be performed

DOE Study of a Front Crash

- Load case: frontal impact of a car on a rigid barrier
- Model from NCAC (National Crash Analysis Center)
<http://www.ncac.gwu.edu>

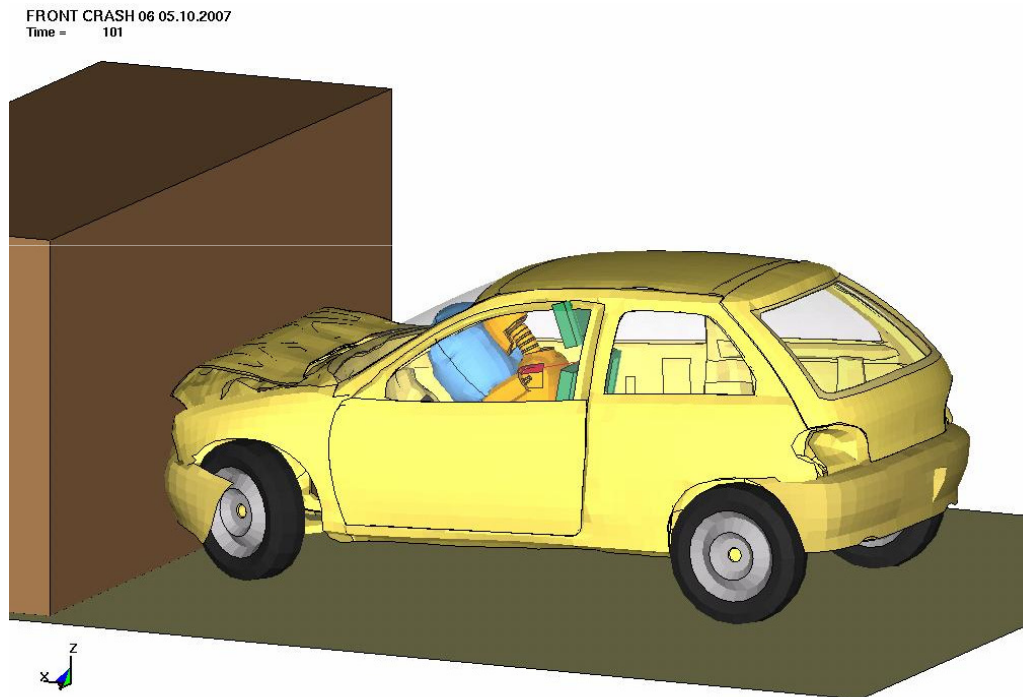

Problem description

- 6 design variables
 - sheet thicknesses of highlighted parts

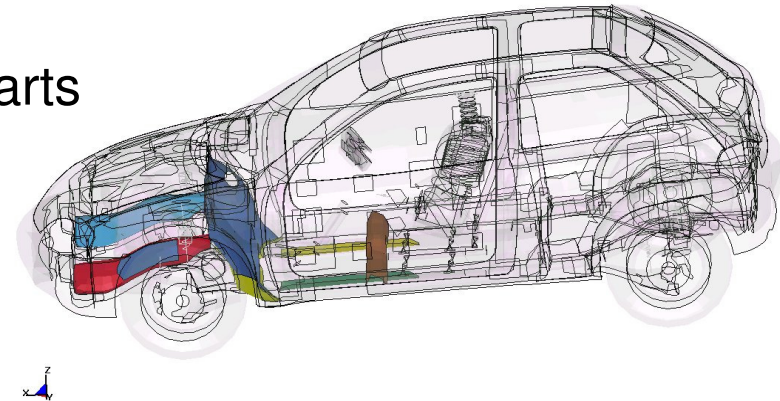

- Responses
 - Chest acceleration of dummy
 - Forces evaluated at 2 cross sections
 - Constraint on mass of vehicle

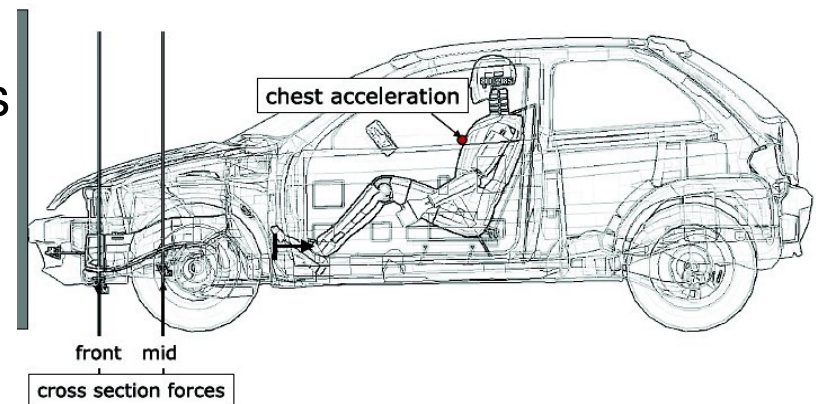

- 250 LS-DYNA simulations
- Sensitivities evaluated on RBF metamodel

Visualization

➤ Correlation Matrix

- Scatter plots, histograms, linear correlation coefficient evaluated using values from simulations

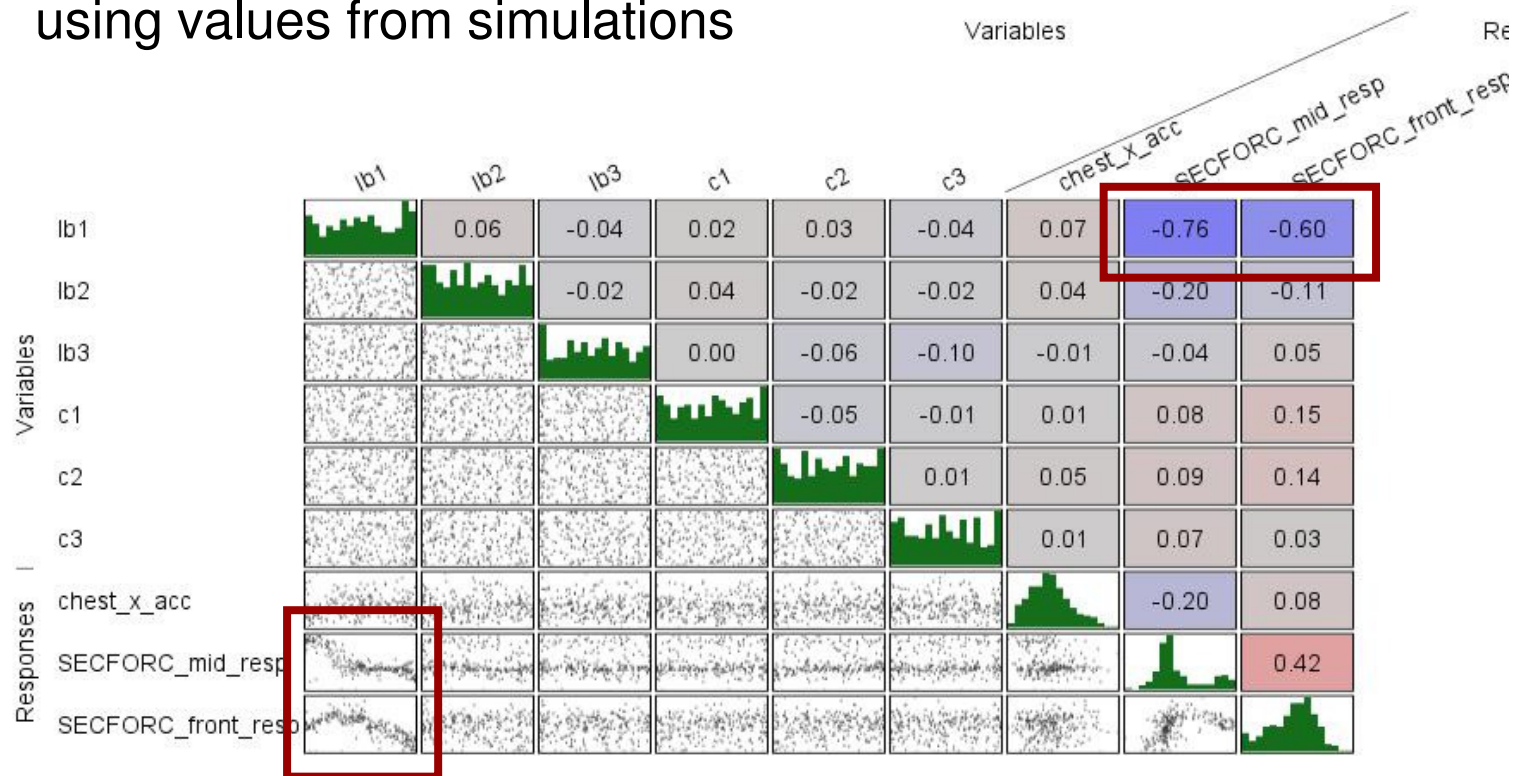

→ *lb1* has a strong effect onto the section forces

→ all variables are insignificant on the chest acceleration

Visualization

- ANOVA (Analysis of Variance) calculated on metamodel

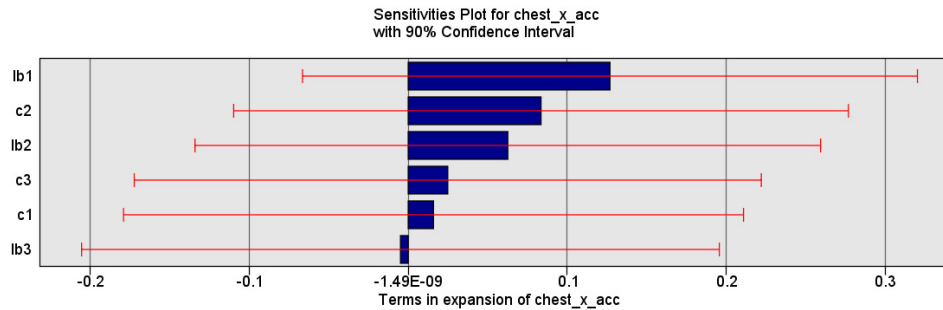

Not meaningful
→ large red error bars

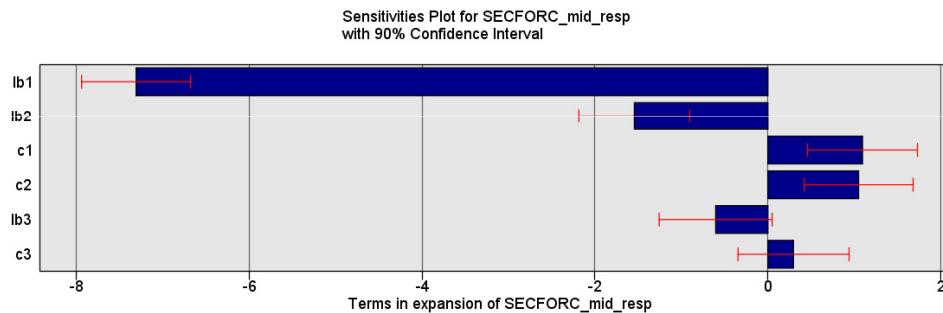

lb1 strong effect
on section forces
→ agreement with
correlation matrix
results

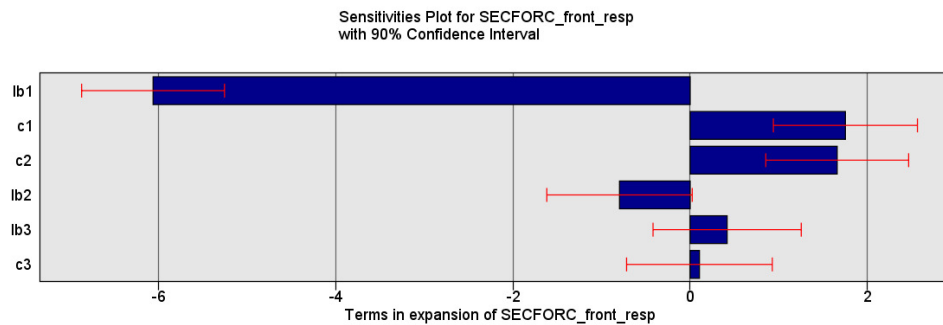

Visualization

- Non-linear sensitivities: global sensitivities (Sobol)
- Each bar represents the contribution of a particular variable to the variance of the respective response

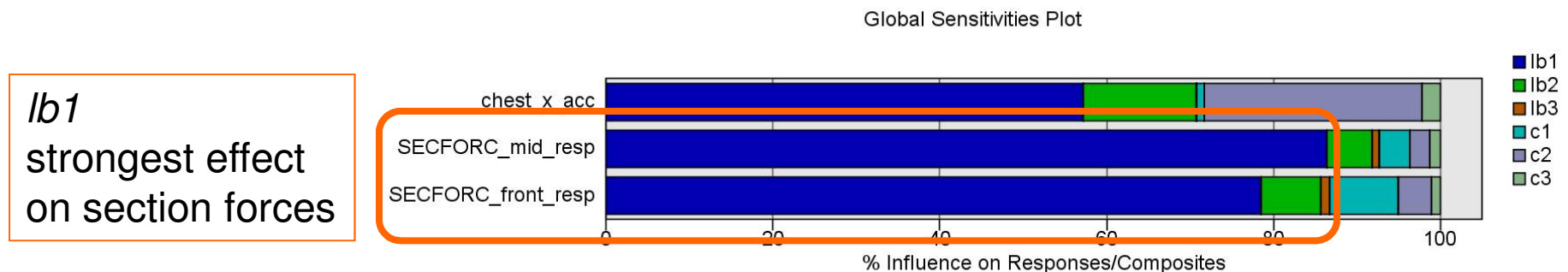
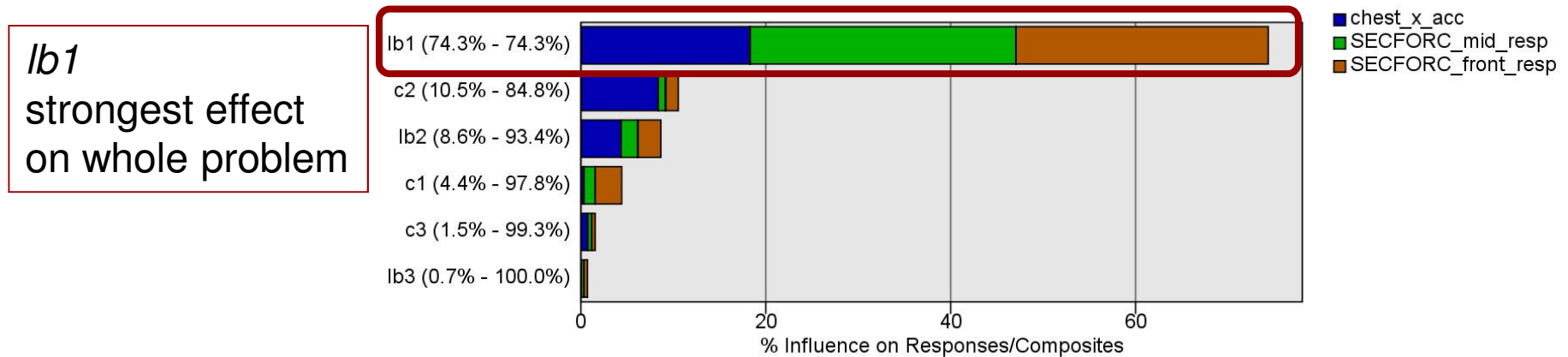

Visualization

- Nonlinear sensitivities
- *lb1* also has a strong effect on the chest acceleration

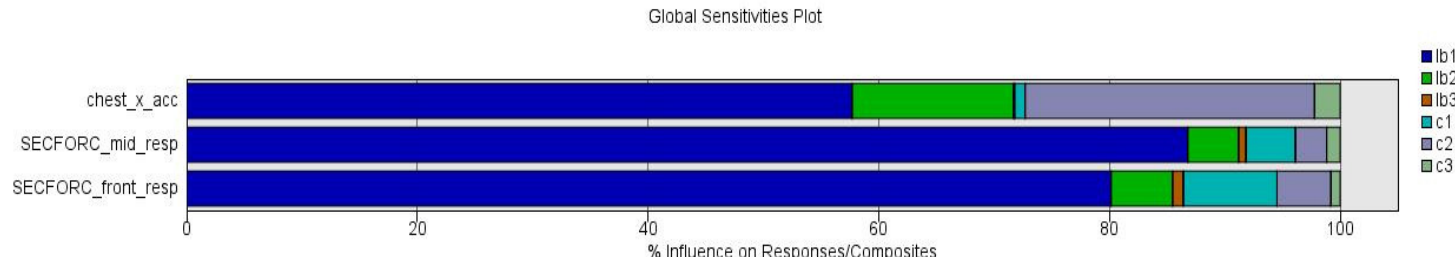

	chest_x_acc	SECFORC_mid_resp	SECFORC_front_resp
lb1	0.07	-0.76	-0.60
lb2	0.04	-0.20	-0.11
lb3	-0.01	-0.04	0.05
c1	0.01	0.08	0.15
c2	0.05	0.09	0.14
c3	0.01	0.07	0.03

	Total variance
chest_x_accel	0.0013
SECFORC_mid_resp	5.16
SECFORC_front_resp	4.73

- Total variance of chest acceleration small → correlation coefficient small

Visualization

- linear and non-linear sensitivities → *lb1* is the most sensitive variable on *SECFORC_front_resp*,
- percentage in comparison to the other variables is higher for the non-linear correlation

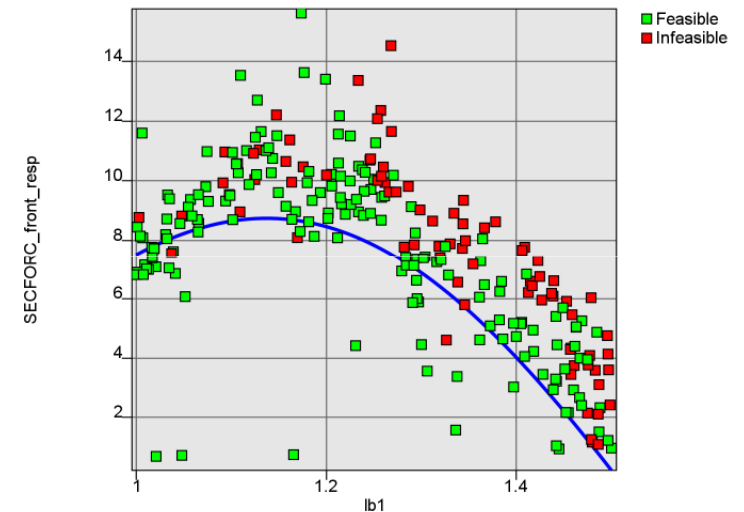
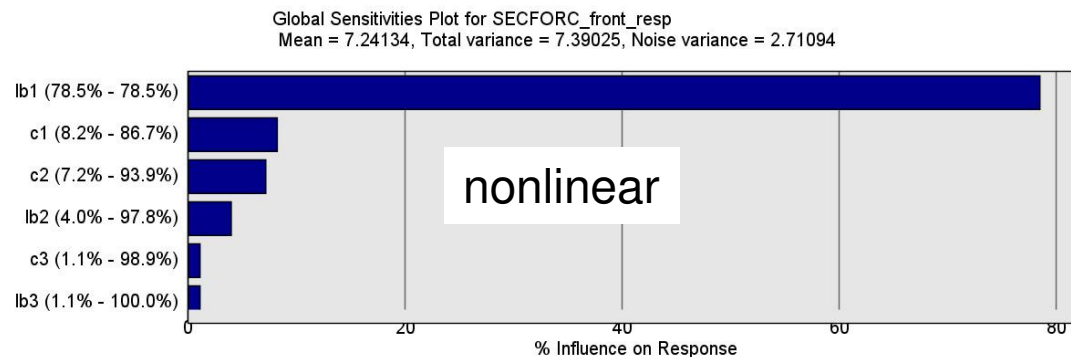
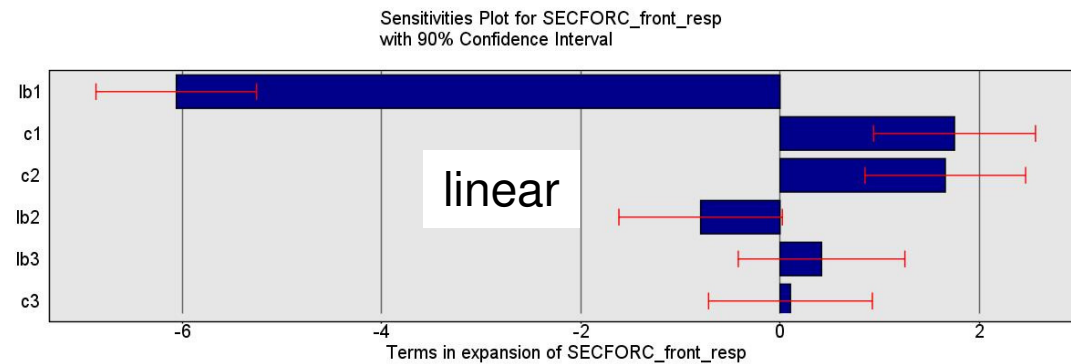

→ quadratic correlation is not detected completely by linear correlation

Visualization

- Interpolator Plot – 2D surface plots
 - comparing the influence of variables on several responses
 - find feasible regions in the design space

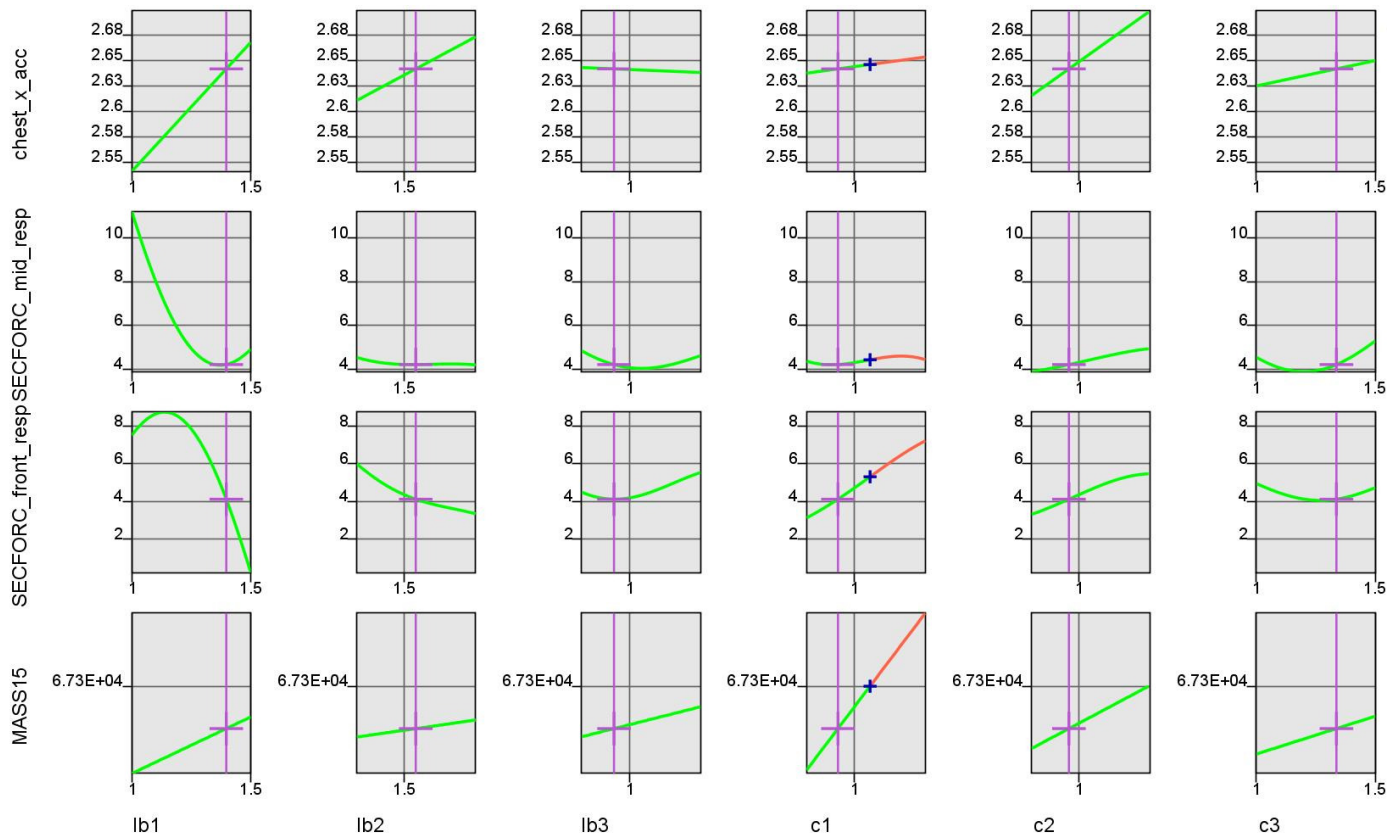

+ MASS15 < 6.73e+04

- feasible
- infeasible
- + predicted value for selected variable values

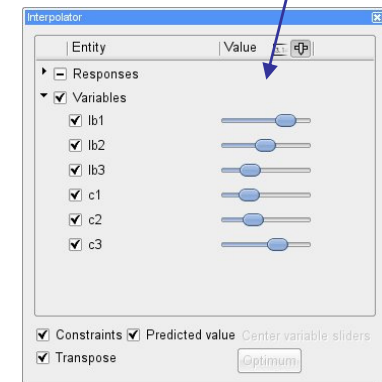

Summary

The post-processing features of LS-OPT 4.1 have improvements in

- visualizing results of multi-objective optimization
 - SOM plot completes the visualization of high dimensional data together with
 - Tradeoff Plot
 - Parallel Coordinate Plot
 - HRV Plot ()
- visualization of curve data
 - histories from simulation results
 - extension of the meta-models on curve data
 - predicted histories
- visualization of sensitivities
 - features to visualize non-linear sensitivities (Sobol)

} already available
in LS-OPT 4.0